

# A95

## Electromechanical submersible level controls for open tanks

Suitable for monophasic pumps with direct control to adjust levels of clear or contaminated water, acid or alkaline aqueous solutions of any density. Do not use for ketonic and aromatic hydrocarbons.

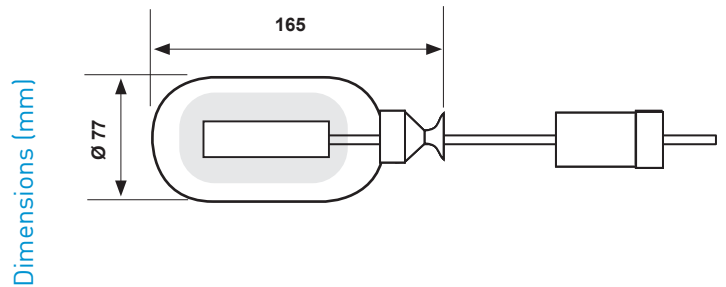

	Cable type	Cable length mt	Contacts rating	Maximum pressure	Maximum liquid temperature	Protection degree	Availability
A95A	PVC	3	10(4)A 250Vca	10 bar	60 °C	IP68	in stock
A95AS1	PVC	5	10(4)A 250Vca	10 bar	60 °C	IP68	in stock
A95B	PVC	10	10(4)A 250Vca	10 bar	60 °C	IP68	in stock
A95BS1	PVC	15	10(4)A 250Vca	10 bar	60 °C	IP68	in stock
A95AS2	neoprene	3	10(4)A 250Vca	10 bar	45 °C	IP68	on request
A95AS3	neoprene	5	10(4)A 250Vca	10 bar	45 °C	IP68	on request
A95BS4	neoprene	10	10(4)A 250Vca	10 bar	45 °C	IP68	on request
A95BS5	neoprene	15	10(4)A 250Vca	10 bar	45 °C	IP68	on request
A95BS6	neoprene	20	10(4)A 250Vca	10 bar	45 °C	IP68	on request
A95BS7	neoprene	25	10(4)A 250Vca	10 bar	45 °C	IP68	on request

## ELECTRICAL FEATURES

Electrical SPDT switch with one way and 2 positions.  
 Electrical cable type A05VV-F 3x1 RF60 CEI-UNEL 35746.  
 Double insulation: 4kW.

WIRING DIAGRAM FOR EMPTYNG PUMP

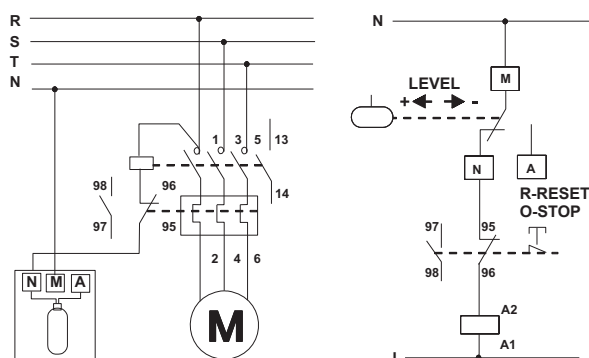

WIRING DIAGRAM FOR FILLING PUMP

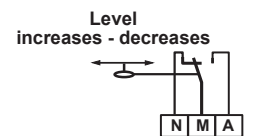
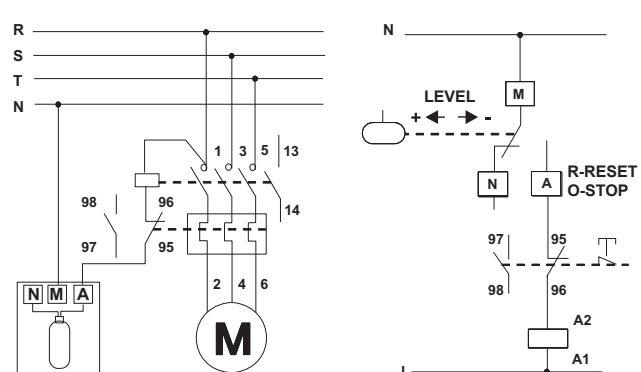

# HOMOLOGATION AND STANDARDS

Conformity with EN 60730-1, 60730-2-16.

Homologation TÜV 

## INSTALLATION

### INSTALLATION EXAMPLE

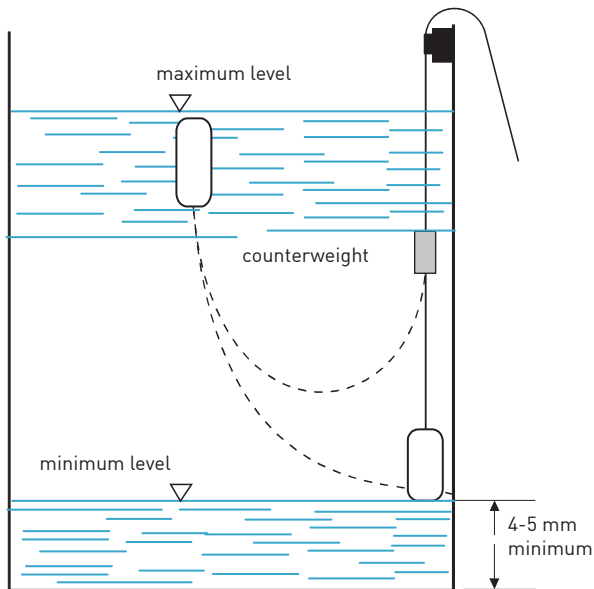

## OPERATION

Suitable for water

Waterproof float

Level control by mean of floats to be made by setting the counterweight position

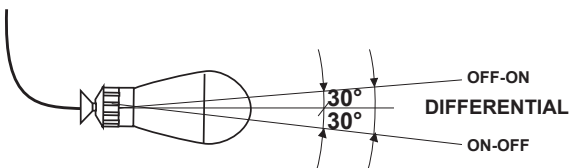

## FEATURES

Blow moulded moplen outer casing, chemical resistant and shockproof.

Intermediate casing filled with polyurethane foam.

In the inner side is located a two-channel electrical device with two positions.

Working area of the electrical device is made of lead to prevent blocking and oxidation.

Adjustable counterweight position to select the level differential.

Moplen blow moulded cable gland on the electrical cable.

Double insulation.

Test class: II.

Storage and transport temperature:  $-25 \div 60^{\circ}\text{C}$ .

A95A Unit weight 0,7 Kg.

A95B Unit weight 1,3 Kg.