

# HEAT RECOVERY UNITS

## ASPIRLIGHT BP SERIES

- Vertical (wall or floor) or horizontal (false ceiling) installation
- Suitable for rooms up to 130 m<sup>2</sup>
- High output > 90%
- Automatic by-pass

### DESCRIPTION:

Dual flow ventilation unit with very high efficiency heat recovery unit, suitable for the controlled mechanical ventilation of residential and commercial buildings.

ASPIRLIGHT BP recovers heat, which would otherwise be lost, from the extracted air and transfers it to the incoming air, thereby significantly increasing its temperature.

The unit is equipped with filters (class G3) on the input and on the return to protect the exchanger and significantly reduce any impurities in the supply/fresh air.

### CHARACTERISTICS:

- 100% integrated and automatic by-pass, to let fresh air in without thermal exchange (free-cooling);
- Duct fitting connections for quick attachment/removal of the unit;
- Expanded polypropylene (EPP) load bearing casing unit;
- Very high efficiency polyethylene (PE) cross flow heat exchangers;
- Heat recovery >90%;
- Maximum flow rate 210 m<sup>3</sup>/h;
- Class G3 filters in input and return;
- 3-speed adjustment with manual control;
- 3-speed adjustment and "timer" function through radio remote control;

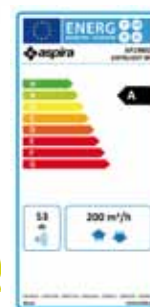

- Possibility of controlling the unit from multiple remote controls (maximum 20);
- Electronically-controlled counterposed impeller motor with only 76W consumption;
- Automatic frost protection;
- Compact and light structure that facilitates handling and installation;
- Possibility of installation in 60cm cabinets;
- Vertical (wall or floor) or horizontal (false ceiling) installation with fastening kit included;
- Access to filters from both sides and inspectable motor unit from the top means air input/ejection to/from outdoors can be installed on either the right or left side;
- BRE certification
- Compliant with Reg. (EU) 1254/2014

### ACCESSORIES AND PARTS:

- Manual control
- RF Wireless Control
- Spare filters class G3-G4-F7

## DIMENSIONS

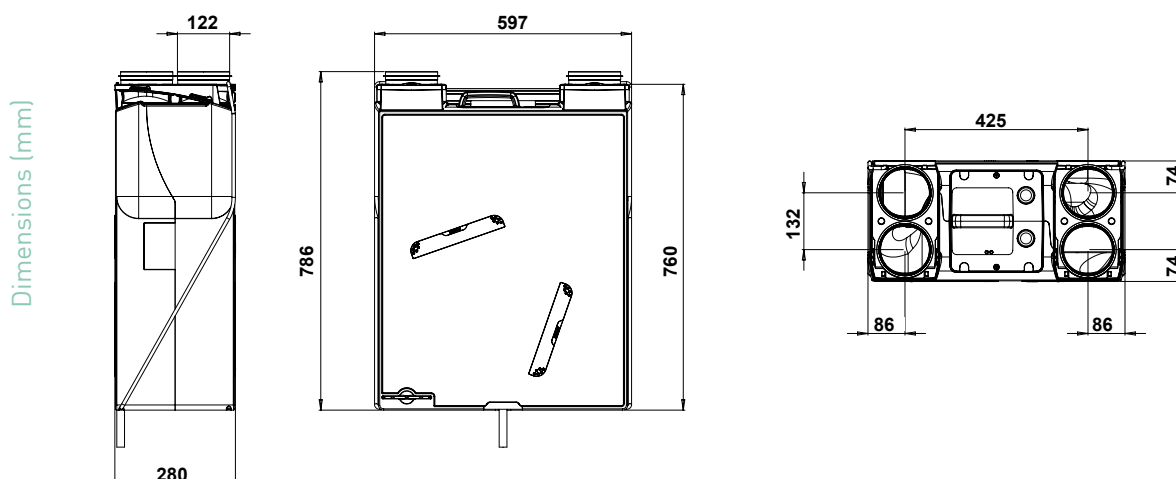

## TECHNICAL FEATURES

CODE	MODEL	Control	m <sup>3</sup> /h	Pa	W	V~	Ph	Hz	IP	Kg
AP19802	ASPIRLIGHT BP	(not included)	210	270	76	230	1	50	X2	12.5

### SPARE FILTER KIT

AP19975	FR 001	Kit of 2 G3 spare filters for ASPIRLIGHT BP								
AP19973	FR 005	Kit of 2 G4 spare filters for ASPIRLIGHT BP								
AP19974	FR 006	Kit of 2 F7 spare filters for ASPIRLIGHT BP								

### RADIO FREQUENCY SPEED REGULATOR (OPTIONAL)

AP19970	RDV-RF	Radio frequency remote control, 3 speeds + timer
---------	--------	--



### MANUAL SPEED REGULATOR (OPTIONAL)

AP19972	RDV-M	Manual control, 3 speeds
---------	-------	--------------------------



## PERFORMANCE

DESCRIPTION		Efficiency	Specific Fan Power	Consumption		Fan speed
		%	(SPF)	Amp	Watt	Rpm
Kitchen + 1 service room	2x15l/s	91	0.37	0.02	5.55	1020
Kitchen + 2 service rooms	2x21l/s	90	0.48	0.04	10.08	1290
Kitchen + 3 service rooms	2x27l/s	89	0.65	0.07	17.55	1560
Kitchen + 4 service rooms	2x33l/s	88	0.83	0.12	27.39	1860
Maximum performance	2x140m <sup>3</sup> /h	-	-	0.19	44.1	2130

# RESULTS FROM SAP CALCULATION (standard assessment procedure)

## RIGID DUCT SYSTEM (MINIMUM FLOW RATE)

Extraction terminal configuration	Air flow rate	Fan speed control	Fan specific power (W/l/s)	Heat exchanger efficiency (%)	Energy savings compatible with best output
Kitchen + 1 service room	54 m <sup>3</sup> /h – 15 l/s	100% variable	0.37	91	Yes
Kitchen + 2 service rooms	75 m <sup>3</sup> /h – 21 l/s	100% variable	0.48	90	Yes
Kitchen + 3 service rooms	97 m <sup>3</sup> /h – 27 l/s	100% variable	0.65	89	Yes
Kitchen + 4 service rooms	119 m <sup>3</sup> /h – 33 l/s	100% variable	0.83	88	Yes

## CHARACTERISTIC CURVES

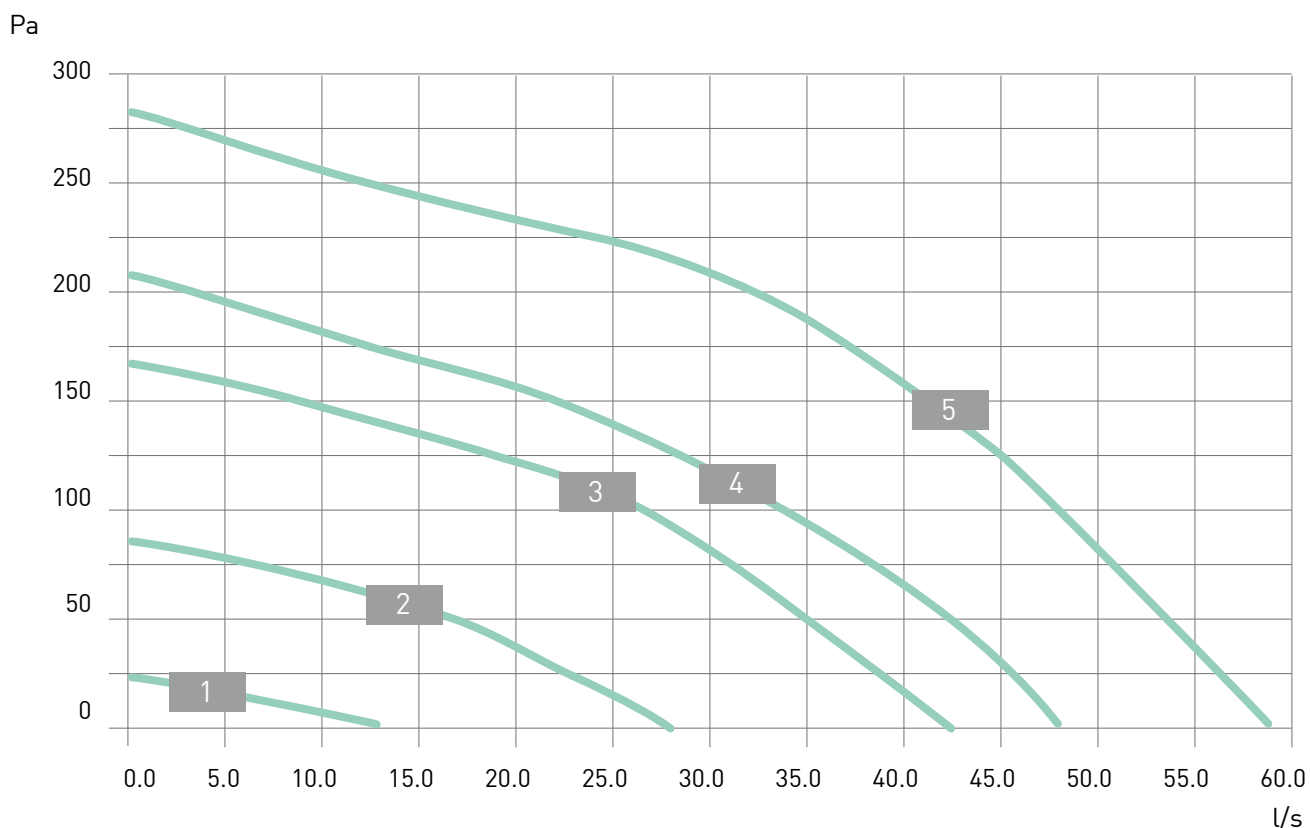

### SPEED / setting

- 1 MIN / min
- 2 MIN / preset
- 3 MIN / max = MAX / min
- 4 MAX / preset
- 5 MAX / max

# NOISE LEVEL LW(A)

IRRADIATION			Total	63 Hz	125 Hz	250 Hz	500 Hz	1000 Hz	2000 Hz	4000 Hz	8000 Hz
			[dB(A)]	[dB]	[dB]	[dB]	[dB]	[dB]	[dB]	[dB]	[dB]
54 m <sup>3</sup> /h	15 l/s	17 Pa	37.5	47.8	53.9	43.5	37.1	29.3	23.8	18.9	18.9
76 m <sup>3</sup> /h	21 l/s	22 Pa	38.0	46.4	47.1	46.9	40.6	34.6	27.8	19.4	19.1
86 m <sup>3</sup> /h	24 l/s	100 Pa	46.0	48.3	52.6	54.9	52.1	45.9	40.6	31.1	27.8
86 m <sup>3</sup> /h	24 l/s	150 Pa	52.0	51.6	55.9	57.8	57.4	50.7	46.2	37.0	26.7
97 m <sup>3</sup> /h	27 l/s	32 Pa	43.0	46.0	51.7	51.1	45.4	40.5	34.5	24.7	19.3
119 m <sup>3</sup> /h	33 l/s	47 Pa	46.0	49.4	49.3	52.9	50.5	45.0	39.5	29.3	27.5
125 m <sup>3</sup> /h	35 l/s	100 Pa	51.5	50.5	56.7	56.7	57.1	49.9	45.2	35.8	25.1
140 m <sup>3</sup> /h	39 l/s	60 Pa	51.0	50.9	56.1	55.9	57.4	49.1	43.6	33.9	27.0
150 m <sup>3</sup> /h	42 l/s	150 Pa	52	53.4	60.6	60.8	61.3	55.0	50.4	41.6	30.0
175 m <sup>3</sup> /h	49 l/s	100 Pa	52.5	51.6	61.0	60.6	61.7	54.8	50.3	41.5	30.1

# PLANT COMPONENTS

## INSTALLATION DIAGRAM

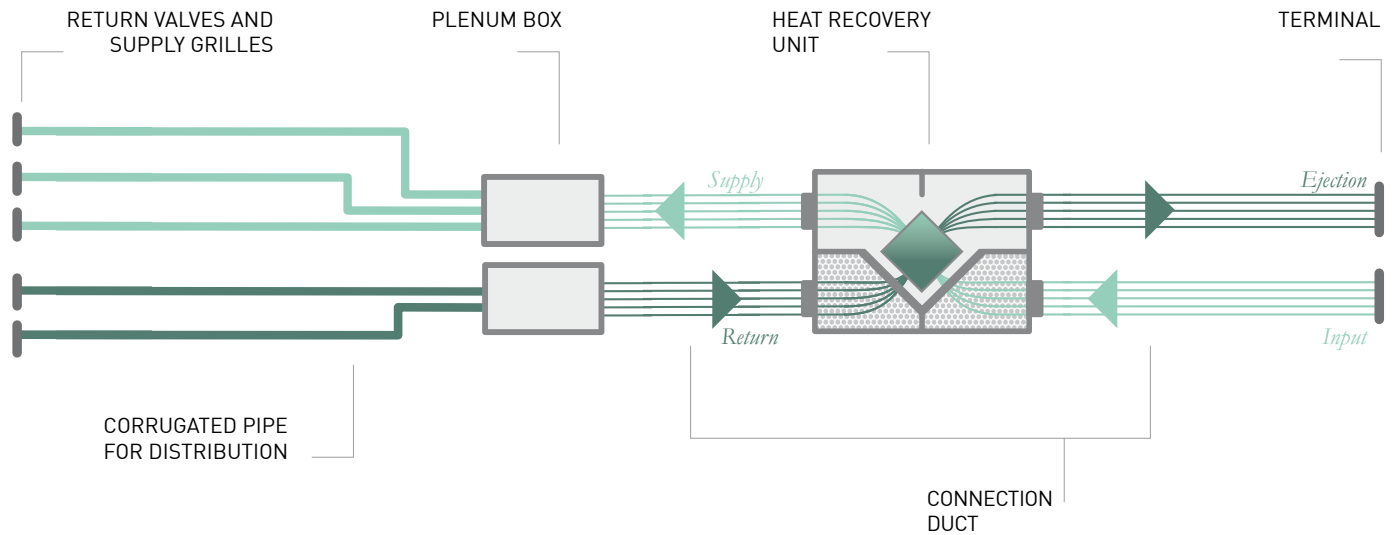

## TERMINAL

### EXTERNAL AIR INPUT TERMINAL

CODE	MODEL	colour	Ø
AP19900	TPE-150 N	■ BLACK	150 mm
AP19901	TPE-150 B	□ WHITE	150 mm
AP19902	TPE-150 G	■ GREY	150 mm
AP19903	TPE-180 N	■ BLACK	180 mm
AP19904	TPE-180 B	□ WHITE	180 mm
AP19905	TPE-180 G	■ GREY	180 mm



### EXTERNAL AIR EJECTION TERMINAL

CODE	MODEL	Length	Ø
AP19906	TT-150	Extension from roof 550 mm 1750 mm	150 mm
AP19907	TT-180	Extension from roof 550 mm 1750 mm	180 mm



# CONNECTION DUCT

## EPP ANTI-CONDENSATION DUCT

CODE	MODEL	length	Ø int.	Ø ext.
AP19908	CPE-150	Duct 1 metre	150 mm	180 mm
AP19909	CPE-180	Duct 1 metre	180 mm	210 mm

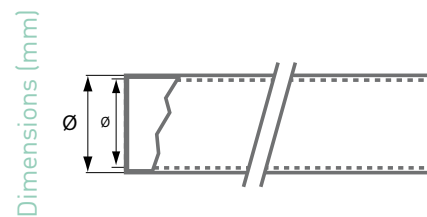

## 90° EPP CURVE

CODE	MODEL	Ø int.	Ø ext.
AP19910	CV90-150	150 mm	180 mm
AP19911	CV90-180	180 mm	210 mm

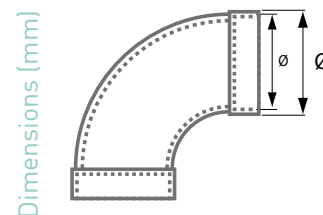

## 45° EPP CURVE

CODE	MODEL	Ø int.	Ø ext.
AP19912	CV45-150	150 mm	180 mm
AP19913	CV45-180	180 mm	210 mm

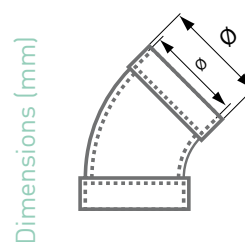

## EPP FITTING

CODE	MODEL	Ø int.	Ø ext.
AP19914	RC-150	150 mm	180 mm
AP19915	RC-180	180 mm	210 mm

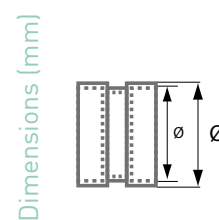

## FLEXIBLE ALUMINIUM DUCT

Flexible double wall aluminium duct reinforced with steel wire spiral.

CODE	MODEL	material	length	Ø
AP19710	TFA 102/10	AL	10 m roll	102 mm
AP19711	TFA 127/10	AL	10 m roll	127 mm
AP19712	TFA 152/10	AL	10 m roll	152 mm
AP19713	TFA 160/10	AL	10 m roll	160 mm
AP19714	TFA 204/10	AL	10 m roll	204 mm



## FLEXIBLE ALUMINIUM INSULATED DUCT

Flexible aluminium and polyester duct with internal fibreglass insulating layer with 25 mm thickness.

CODE	MODEL	material	length	Ø
AP19715	TFAI 102/10	AL	10 m roll	102 mm
AP19716	TFAI 127/10	AL	10 m roll	127 mm
AP19717	TFAI 152/10	AL	10 m roll	152 mm
AP19718	TFAI 160/10	AL	10 m roll	160 mm
AP19719	TFAI 204/10	AL	10 m roll	204 mm



## ADAPTER FOR FLEXIBLE PIPE DN152 - ASPIRCOMFORT

CODE	MODEL	for	material	Ø
AP19751	AD15-15	TFA152/10, TFAI 152/10 and ASPIRCOMFORT	Al ZN	150 mm

# PLENUM BOX

## INSULATED DISTRIBUTION PLENUM

CODE	MOD.	No. connections	m <sup>3</sup> /h	mm			
				length	width	height	∅
AP19921	PB17-150	17	350	680	200	150	150
AP19922	PB14-150	14	300	560	200	150	150
AP19923	PB11-150	11	225	430	200	150	150
AP19924	PB8-150	8	150	310	200	150	150
AP19920	PB5-125	5	140	215	215	145	125

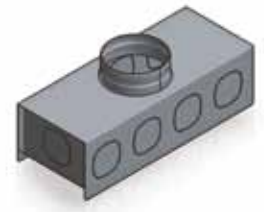

## INSPECTABLE DISTRIBUTION PLENUM

CODE	MODEL		No. connections	m <sup>3</sup> /h	mm			
					a	b	c	∅
AP19925	PDS	(for AP19926)	1	350	603	233	207	150 / 180
AP19926	PDI	(for AP19925)	12	350	603	271	207	DN75 / DN90



## BOX PLENUM CONNECTION

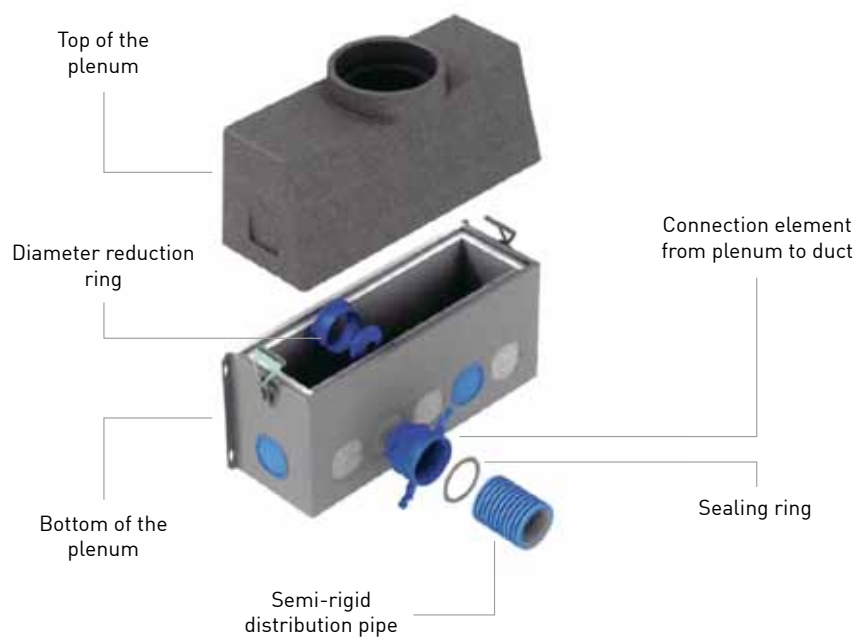



# DISTRIBUTION PIPES

## CORRUGATED PIPE FOR THE DISTRIBUTION OF THE SUPPLY OR RETURN AIR

CODE	MODEL	colour / type	roll length	Ø internal	DN Ø external
AP19930	TCR-75	■ RED / return	50 m	63 mm	75 mm
AP19931	TCR-90	■ RED / return	50 m	76 mm	90 mm



## CORRUGATED PIPE FOR THE DISTRIBUTION OF THE SUPPLY OR RETURN AIR

Made of self-extinguishing HDPE, with UV treatment and internal anti-static treatment

CODE	MODEL	colour / type	roll length	Ø internal	DN Ø external
AP19994	TCRM-75	■ BLUE	50 m	63 mm	75 mm
AP19995	TCRM-90	■ BLUE	50 m	76 mm	90 mm



## 90° FITTING BETWEEN TWO CORRUGATED PIPES AND THE RETURN VALVE

CODE	MODEL		DN
AP19936	RA2V-75	90° fitting between two corrugated pipes DN75 and the return valve	75 mm



## 90° FITTING BETWEEN CORRUGATED PIPE AND THE RETURN VALVE

CODE	MOD.		DN
AP19937	RA1V-90	90° fitting between corrugated pipe DN90 and the return valve	90 mm



## STRAIGHT FITTING BETWEEN TWO CORRUGATED PIPES AND THE RETURN VALVE

CODE	MOD.		DN
AP19938	RR2V-75	Straight fitting between two corrugated pipes DN75 and the return valve	75 mm



## STRAIGHT FITTING BETWEEN CORRUGATED PIPE AND THE RETURN VALVE

CODE	MOD.		DN
AP19939	RR1V-90	Straight fitting between corrugated pipe DN90 and distribution/return terminal	90 mm



---

## FITTING FOR CORRUGATED PIPE

CODE	MODEL		DN
AP19932	RTC-75	Fitting for corrugated pipe DN75 with sealing rings.	75 mm
AP19933	RTC-90	Fitting for corrugated pipe DN90 with sealing rings.	90 mm



---

## FITTING BETWEEN CORRUGATED PIPE AND PLENUM

CODE	MODEL		DN
AP19934	RTP-75	Fitting between corrugated pipe DN75 and plenum with sealing rings	75 mm
AP19935	RTP-90	Fitting between corrugated pipe DN90 and plenum with sealing rings	90 mm



---

## BRACKET TO ANCHOR CORRUGATED PIPE

CODE	MOD.		No. of pieces pack	DN
AP19940	STC-75	Bracket to anchor corrugated pipe DN75	10	75 mm
AP19941	STC-90	Bracket to anchor corrugated pipe DN90	10	90 mm



---

## DUST CAP

CODE	MOD.		No. of pieces pack	DN
AP19942	TP-75	Dust cap for corrugated pipe DN75 and ducts	10	75 mm
AP19943	TP-90	Dust cap for corrugated pipe DN90 and ducts	10	90 mm



---

## CONTROL DIAPHRAGM

CODE	MOD.		No. of pieces pack
AP19944	DFR	Flow rate control diaphragm	1



# AIR RETURN AND SUPPLY

## CONE-SHAPED RETURN VALVE

CODE	MOD.	m <sup>3</sup> /hreturn	Ø
AP19945	VDC-1	50 ÷ 75 adjustable	115 mm



## CONE-SHAPED RETURN VALVE

CODE	MOD.	m <sup>3</sup> /h	mm	
			ØA	ØC
AP19780	VVA-100	35 ÷ 120	148	99
AP19781	VVA-125	40 ÷ 170	168	124
AP19782	VVA-160	60 ÷ 220	186	149/159
AP19783	VVA-200	70 ÷ 330	240	198

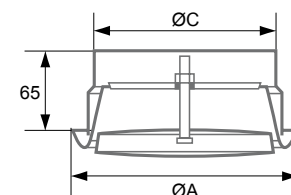

## STEEL SUPPLY GRILLE

CODE	MOD.	mm		holes	colour	m <sup>3</sup> /h
		width	height			
AP19947	GDA-70G	260	155	slot	■ SILVER	70
AP19948	GDR-70G			round	■ SILVER	70
AP19949	GDQ-70G			square	■ SILVER	70
AP19950	GDA-70B			slot	□ WHITE	70
AP19951	GDR-70B			round	□ WHITE	70
AP19952	GDQ-70B			square	□ WHITE	70



## PLENUM FOR SUPPLY GRILLE

Insulated galvanised sheet metal plenum for rectangular grilles.

CODE	MOD.	mm		
		depth	width	height
AP19953	PGR	140	232	127



CODE	MOD.	description	mm		
			depth	width	height
AP19963	PGR 90L	with side fitting DN90	100	232	127
AP19964	PGR 75L	with side fitting DN75	85	232	127
AP19965	PGR 90H	with top fitting DN90	100	232	127
AP19966	PGR 75H	with top fitting DN75	85	232	127

