

# CENTRIFUGAL FANS

## CTF SERIES

➔ for duct application

➔ for wall and window installation



Ø 100 mm

### DESCRIPTION:

CTF line is composed from a product range with unique design and unique dimensions. Both, performances and the silent functioning mode, can easily satisfy ventilation needs of small, medium and large rooms. The practical front cover clip-on system and the tear-proof power cable system, make the CTF fan line extremely simple and fast to be installed. The butterfly shutter prevents the return of smoke and odours in the environment and it functions as a particle filter (for grease, dust, etc.), completing in this way the technical features of these high quality products.

### MAIN FEATURES:

- Adapter ring for drain holes Ø120 mm, supplied.
- Made of shockproof and heat resistant plastic (ABS).
- Induction motor - Is Class B - 2100 RPM with self-lubricating bushings.
- Motor protection through a thermal fuse.
- Operation signal lamp.
- Non-return butterfly shutter for preventing the smoke and odours returning in the environment.



IPX4 CE

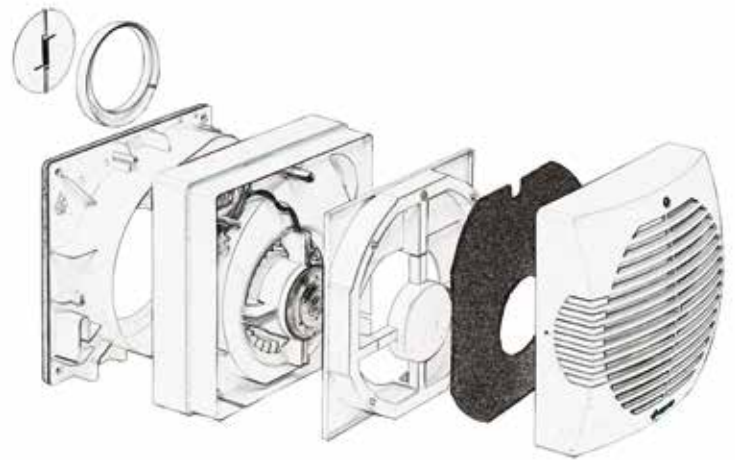

- Protective filter, supplied.
- Vibration gasket, supplied.

### SPARE PARTS:

- Acrylic filter for retaining the solid particles (grease, dust, etc.).

## DIMENSIONS

Dimensions (mm)

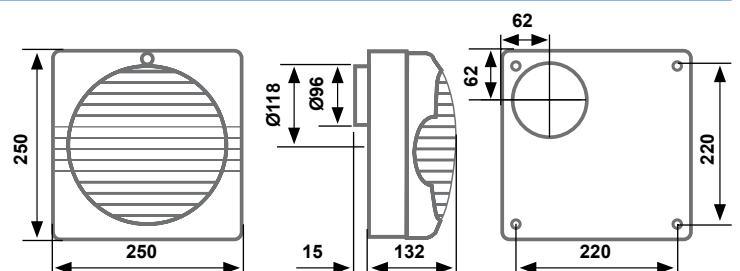

# TECHNICAL SPECIFICATIONS

## STANDARD - S

CODE	MODEL	m <sup>3</sup> /hr	Pt max mmH <sub>2</sub> O	V	Hz	W	dB(A) 1,5mt	Kg
AP2006	CTF 100 S	100	15	230	50	18	48	2,08
AP2113	CTF 170 S	165	19	230	50	48	53	2,36
AP2162	CTF 250 S	230	24	230	50	70	57	2,52

## WITH PULL CORD - PC

CODE	MODEL	m <sup>3</sup> /hr	Pt max mmH <sub>2</sub> O	V	Hz	W	dB(A) 1,5mt	Kg
AP2014	CTF 100 PC	100	15	230	50	18	48	2,08
AP2121	CTF 170 PC	165	19	230	50	48	53	2,36
AP2170	CTF 250 PC	230	24	230	50	70	57	2,52

## WITH ELECTRONIC TIMER - T

The fan starts to operate when the light switched on and it continues to work for a programmable period of time between 45 seconds and 30 minutes, after the light is switched off.

CODE	MODEL	m <sup>3</sup> /hr	Pt max mmH <sub>2</sub> O	V	Hz	W	dB(A) 1,5mt	Kg
AP2022	CTF 100 T	100	15	230	50	18	48	2,08
AP2139	CTF 170 T	165	19	230	50	48	53	2,36
AP2188	CTF 250 T	230	24	230	50	70	57	2,52

## WITH TIMER AND HUMIDITY CONTROL- HTT

The fan automatically starts to operate when the relative humidity level in the room exceeds the pre-set value and it continues to operate until the RH level returns below the pre-set threshold. When this threshold is reached, TIMER functioning allows the fan to continue operating for a programmable period of time between 45 seconds and 30 minutes, to further reduce the relative humidity value in the room. The relative humidity value can be set from a minimum of 40% RH to a maximum of 80% RH. This fan can also be used manually, also using the TIMER function.

CODE	MODEL	m <sup>3</sup> /hr	Pt max mmH <sub>2</sub> O	V	Hz	W	dB(A) 1,5mt	Kg
AP2105	CTF 100 HTT	100	15	230	50	18	48	2,08
AP2154	CTF 170 HTT	165	19	230	50	48	53	2,36
AP2204	CTF 250 HTT	230	24	230	50	70	57	2,52

## SPARE PARTS

### ACRYLIC FILTER

CODE	MODEL
AP2220	6 FILTERS CTF

# CHARACTERISTIC CURVES

## CTF SERIES 100

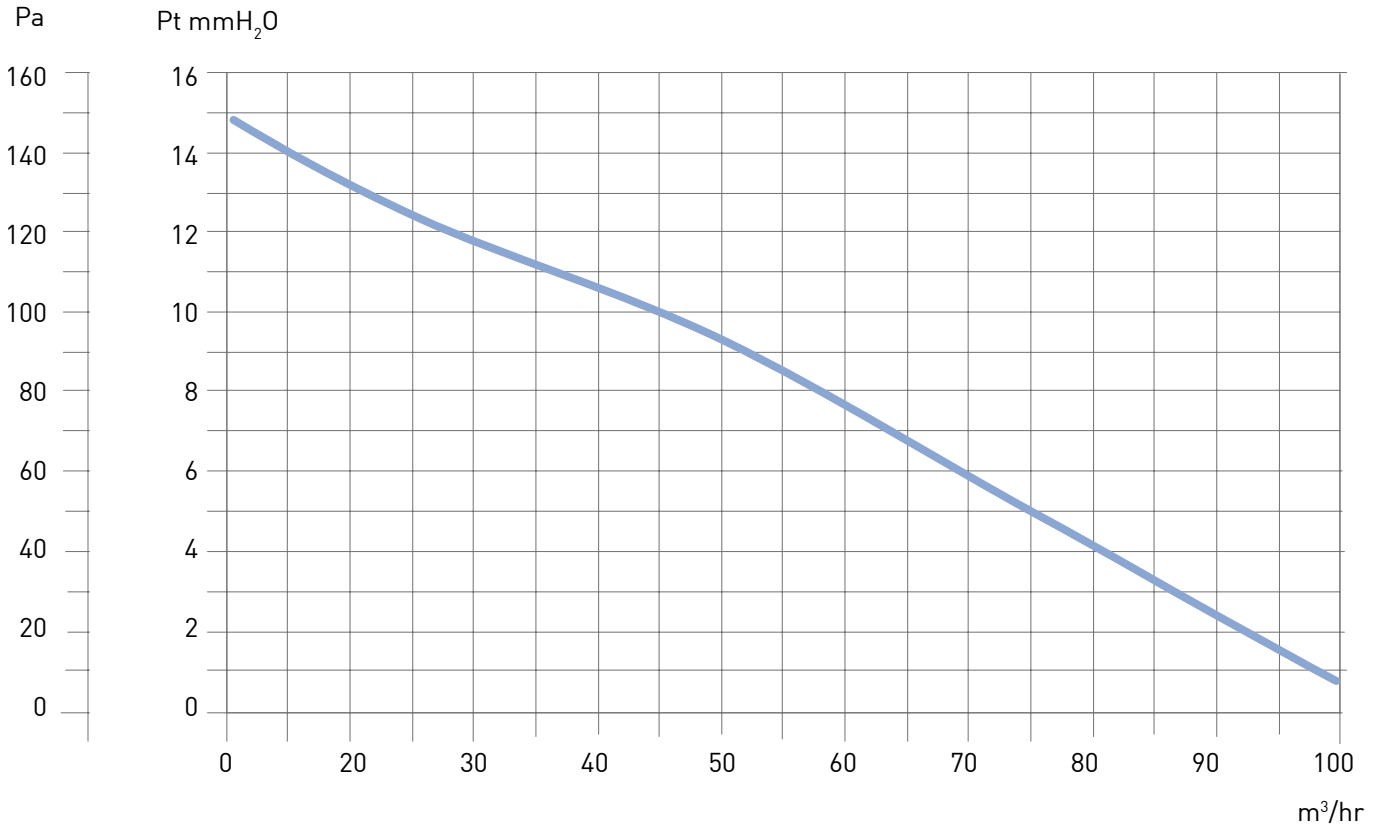

## CTF SERIES 170

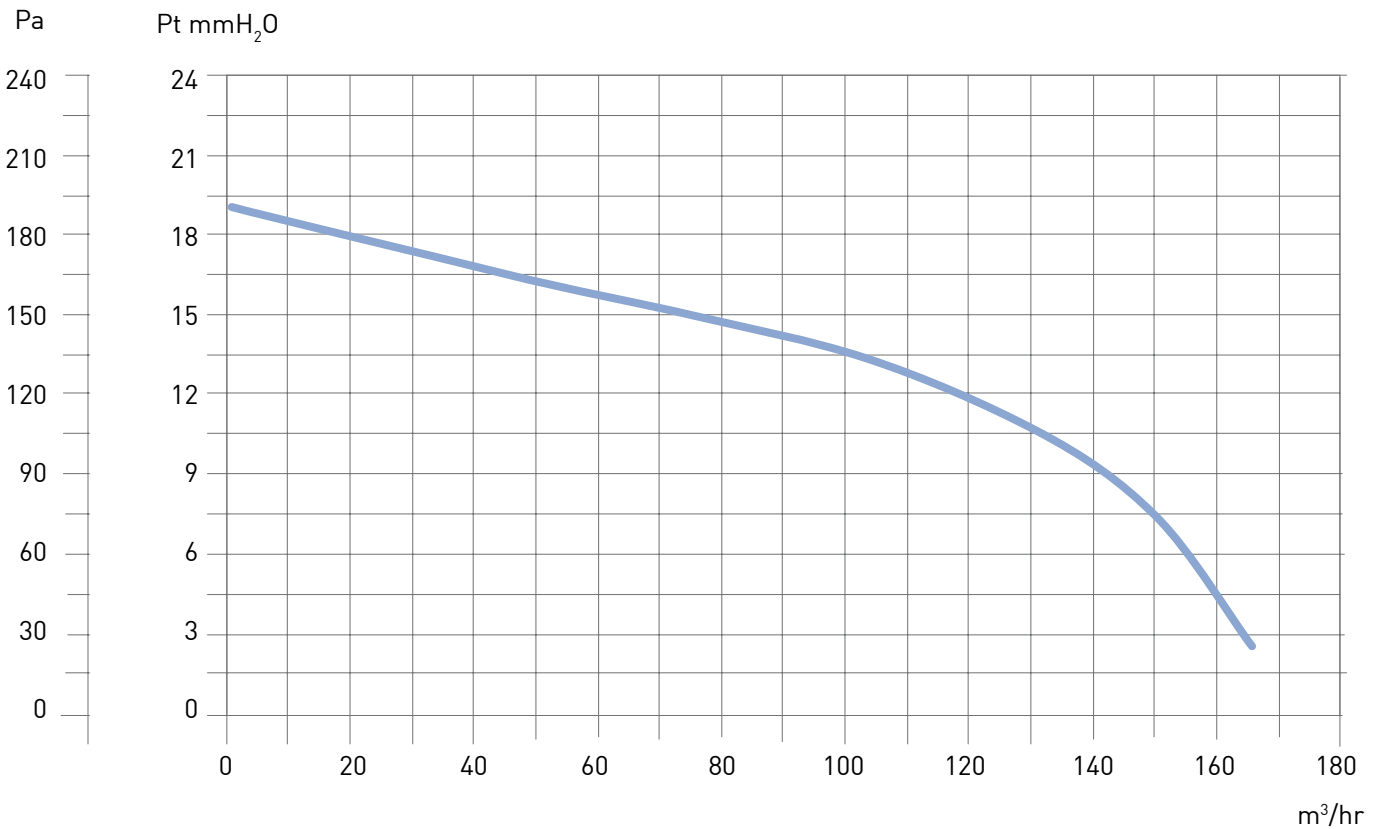

## CTF SERIES 250

