

FLOW SWITCHES FF81 for pipes from G1 to G4 FF84 for pipes from G1 to G10

english FF81-FF84

GENERAL CHARACTERISTICS

Flow switches are suitable to control and adjust air in conditioning.

FUNCTIONING AND INSTALLATION

A flexible paddle works on a lever starting a microswitch in SPDT. The electrical connection can be prearranged to control pumps, burners, compressors, motoroperated valve, signalling alarms.

It is installed on sections of horizontal pipe, far from valves, elbows, irregular flows or discharges.

The straight pipe must be at least 5 times the long of the of the pipe. The flow direction must follow the arrow designed on the instrument. Check the correct installation and the correct functioning, pretending the flow inside the pipe manually pushing the lever until you close the C-NO contact. Then check the opening of the contact.

ON PIPELINES G1

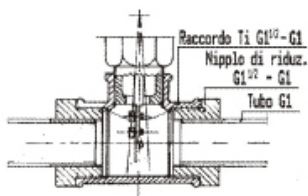

ON PIPELINES FROM G2 TO G10

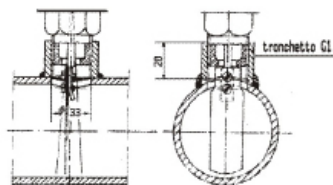

TECHNICAL CHARACTERISTICS

FF81: with shock-resistant enclosure, protection degree IP54, sealed gland in nylon G 3/8", lever group from G1" to G4".

FF84: with a inox enclosure, protection degree IP54, sealed-gland in nickel-plated brass G 3/8", lever group from G1" to G10" already mounted).

TECHNICAL CHARACTERISTICS OF BOTH MODELS

Lever group for pipelines in inox AISI 301.

G1" connection.

Electrical connections on 6.3 Faston (on issue).

Calibration screw for the regulation of the intervention point.

Max. temperature of the controlled fluid 110 °C.

Working temperature -20 to 70 °C.

SPDT microswitch.

Conformity with CEI EN 60947-5-1

Nominal insulation tension	Ui 380V-
Continuous duty nominal current	Ith 10A
Operating nominal current le:	220V- 250V-
Resistive load	AC-12 - 10A
Inductive load	AC-15 - 3A
Direct current	DC-13 0,2A -

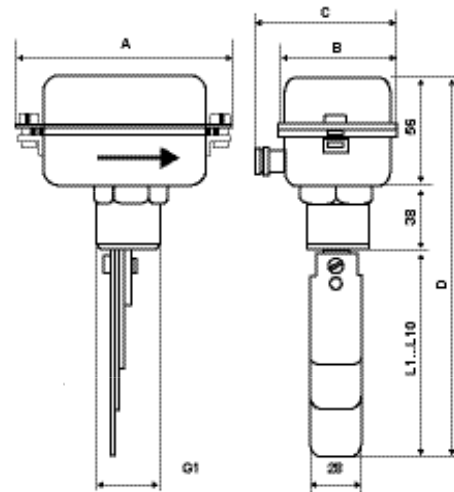

FF81	FF84
A	105 98
B	62 54
C	80 72
D	204 354
L1	28
L2	53
L3	78
L4	103
L6	153
L8	203
L10	253

Dimensions (mm)

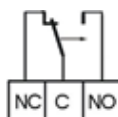
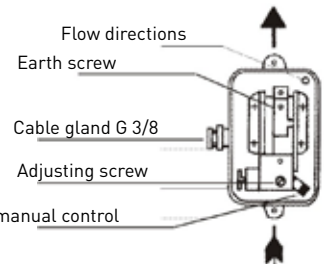
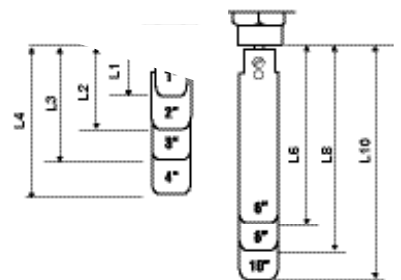

Flow increases open C-NC close C-NO
Flow decreases close C-NC open C-NO

	Pipeline diameter	Minimum Calibration value (dm³/sec) with		Max Calibration value (dm³/sec)		Brass threaded connection	Max. working pressure	Protection degree	Unit weight
		increasing flow	decreasing flow	increasing flow	decreasing flow				
FF81	G 1"	0,26	0,16	0,58	0,53	G1"	10 bar	IP54	0,39
	G 2"	0,8	0,6	1,6	1,7				
	G 3"	1,7	1,2	3,2	3				
FF84	G 4"	2,2	1,7	5,1	4,8	G1"	10 bar	IP54	0,67
	G 6"	4,7	3,4	9	8,5				
	G 8"	12,9	10,7	26	25,2				
	G 10"	26,5	22	43,5	41				