

# ZD..NA

## Normally open electromagnetic safety valves with manual reset

Normally open electromagnetic safety valves for air and non-aggressive gases (according to EN437) with manual reset.

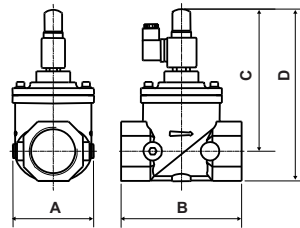

■ ZDEV...15 ÷ 50

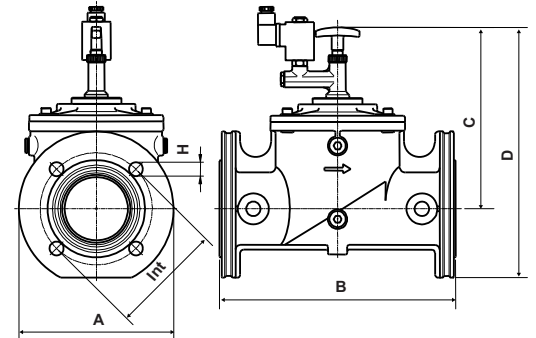

■ ZDEV...65 ÷ 100

DN	A	B	C	D	Int	h
DN15	30	58	115	130	-	-
DN20	35	55	113	130	-	-
DN25	40	62	115	137	-	-
DN32	120	153	170	203	-	-
DN40	120	153	170	203	-	-
DN 50	106	156	175	213	-	-
DN 65	200	305	260	350	145	4x18
DN 80	200	305	260	350	160	8x18
DN 100	252	350	280	410	180	8x18

	Connection type	Passage DN	Power supply	Body	Maximum pressure mbar	Absorption W	Unit weight Kg
ZDVGRM15NA	threaded RP 1/2	15	230Vac 50/60Hz	brass	500	16	0,4
ZDVGRM20NA	threaded RP 3/4	20	230Vac 50/60Hz	brass	500	16	0,6
ZDVGRM25NA	threaded RP 1	25	230Vac 50/60Hz	brass	500	16	0,7
ZDEVRM32NA	threaded RP 1 1/4	32	230Vac 50/60Hz	aluminum	500	16	1,6
ZDEVRM40NA	threaded RP 1 1/2	40	230Vac 50/60Hz	aluminum	500	16	1,6
ZDEVRM50NA	threaded RP 2	50	230Vac 50/60Hz	aluminum	500	16	1,9
ZDEVRMF65NA	flanged DN 65	65	230Vac 50/60Hz	aluminum	500	19	8,2
ZDEVRMF80NA	flanged DN 80	80	230Vac 50/60Hz	aluminum	500	19	8,2
ZDEVRMF100NA	flanged DN 100	100	230Vac 50/60Hz	aluminum	500	19	16
ZDVGRM15NAF	threaded RP 1/2	15	24Vac	brass	500	16	0,4
ZDVGRM20NAF	threaded RP 3/4	20	24Vac	brass	500	16	0,6
ZDVGRM25NAF	threaded RP 1	25	24Vac	brass	500	16	0,7
ZDEVRM32NAF	threaded RP 1 1/4	32	24Vac	aluminum	500	16	1,6
ZDEVRM40NAF	threaded RP 1 1/2	40	24Vac	aluminum	500	16	1,6
ZDEVRM50NAF	threaded RP 2	50	24Vac	aluminum	500	16	1,9
ZDEVRMF65NAF	flanged DN 65	65	24Vac	aluminum	500	19	8,2
ZDEVRMF80NAF	flanged DN 80	80	24Vac	aluminum	500	19	8,2
ZDEVRMF100NAF	flanged DN 100	100	24Vac	aluminum	500	19	16

<sup>1</sup> on opening

# ELECTRICAL CHARACTERISTICS

Rated voltage: 230Vac - 50/60Hz or 24Vac/dc

Upon request valves are available with coils for the following voltages: 110V AC 50/60Hz or 12V AC/DC

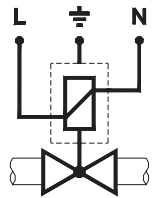

# STANDARDS AND APPROVALS

Complies with 73/23/CEE; 89/336/CEE standards



# INSTALLATION

Check the correspondence between flow direction and the arrow printed on valve body, verify the correct alignment of connecting pipes and allow enough space from the walls to allow free air circulation.

The valve may be mounted with coil in horizontal or vertical position. The coil may be oriented 360 degrees in any direction.

Install the valve in an area protected from rain and water splashes or drops.

For electrical connection remove the cap of the plug and connect power cables to circuit clamps.

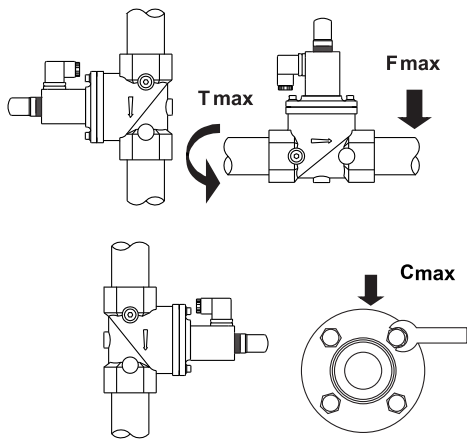

MODEL	Fmax t<10S (Nm)	Tmax (Nm)	Cmax (Nm)
ZDVGRM15...	105	50	-
ZDVGRM20...	225	85	-
ZDVGRM25...	340	125	-
ZDVGRM32...	475	160	-
ZDVGRM40...	610	200	-
ZDVGRM50...	1100	250	-
ZDVGRMF65...	1600	-	50
ZDVGRMF80...	2400	-	50
ZDVGRMF100...	5000	-	50

# OPERATION

Normally open gas safety valve with manual reset.

A manual operation is necessary to open the valve and set the mechanism which allows this state maintaining. The powering by means of line current and/or condenser discharge, induced by the leakage detector, causes mechanism releasing and consequently gas passage closing.

If sensor energizing persists due to the gas presence, the valve remains under voltage and does not allow the reset.

When the causes for blocking have been eliminated, the valve may be reopened by operating it manually.

This type of device, connected with one or more gas leak detectors or alarm signals for carbon monoxide presence, is suitable for performing blocking operations on the gas line.

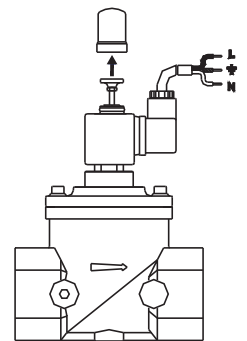

# TECHNICAL FEATURES

Voltage tolerance: -15% / +10%.

Environment temperature: -15°C / +60°C.

Working pressure: 500 mbar Max.

Closing time < 1 second.

Protection degree: IP54.

Cable gland: PG 9.

Pressure inlets: G1/4" on two sides (except models with brass body).

Limit switch: by request from 3/4" to 4".

Gas type: Air and non-aggressive gases (EN 437).

Filter: 600 µm (except models with brass body).