



ASPIRCOMFORT CLASS 620H WI-FI
INSTALLATION, USE AND MAINTENANCE MANUAL

1. GENERAL

1.1 INTRODUCTION

This manual was prepared with the aim of making the installation and management of your system as simple as possible.

By reading and applying the suggestions of this manual, you can achieve the best performance of the purchased product.

We would like to thank you for choosing to purchase one of our products.

Read this file carefully before performing any operation on the unit.

The unit must not be installed, nor must any operation be performed on it, without firstly reading and understanding the entirety of this manual. In particular it is necessary to adopt all of the precautions listed in the manual.

The documentation provided with the unit must be delivered to the system manager for safe keeping (at least 10 years) for future assistance, maintenance and repairs.

Unit installation must take into account the strictly technical needs for good operation, as well as any local legislation in force and specific requirements.

Make sure that when the unit is delivered there are no evident signs of damage caused by transport. If there is, state this on the delivery note.

This manual reflects the state of the art at the time the machine was placed on the market and cannot be regarded as inadequate in the event of subsequent updates on the basis of new experience. The manufacturer reserves the right to update production and manuals, without the obligation to update the previous ones, except in exceptional cases.

Please contact the manufacturer's sales department for further information or updates to the technical documentation and for any proposals to improve this manual. All reports received will be rigorously screened.

1.2 FUNDAMENTAL SAFETY RULES



Remember that the use of products that use electrical energy and water requires certain fundamental safety rules to be followed:

- Unable and unassisted persons are forbidden from using the device.
- It is forbidden to touch the device in bare feet and with wet or damp parts of the body.
- Any cleaning activity is forbidden without firstly disconnecting the device from the electrical power mains by placing the system's main switch on 'off'.
- It is forbidden to modify the safety or regulation devices without the authorisation and indications of the device manufacturer.

- It is forbidden to pull, detach, twist the electrical cables coming out of the device, even if it is disconnected from the electrical power mains.
- It is forbidden to insert objects and substances through the air intake and supply grids.
- It is forbidden to open the access doors to the inside of the device, without firstly placing the system's main switch on 'off'.
- It is forbidden to release and leave packaging material within the reach of children as it is a potential source of danger.
- Comply with the safety distances between the machine and other devices or structures to guarantee enough access space to the unit for maintenance and assistance operations as stated herein.
- The unit's power supply must be provided with electrical cables duly sized for the power of the unit. The voltage and frequency values must match those stated for the respective machines; all machines must be earthed according to the regulations in force in the various countries.

1.3 SYMBOLS

The symbols used in the following file quickly provide information necessary for the correct use of the unit.

Safety symbols



ATTENTION

Authorised personnel only. This means that the stated operations are important to safe machine operation.



DANGER

Risk of electric shock. This means that failure to comply with the warnings poses the risk of electric shock.



DANGER

This means that failure to comply with the warnings poses the risk of injury to the exposed persons.



WARNING

This means that failure to comply with the warnings poses the risk of damage to the unit or system.



DANGER

This means that there are moving parts and poses the risk of harm to exposed persons.

1.4 WARNINGS



The unit must be installed by qualified and authorised personnel according to the rules in force in the various countries.

If installation is not carried out, this could lead to a situation of danger.



Avoid installing the unit in very damp rooms or where there are large sources of heat.



On the electric side, to prevent any risk of electrocution, it is essential to disconnect the main switch before setting up the electrical connections and performing any maintenance operation.



If there are any water leaks from inside the unit, place the system's main switch on 'Off', close the water valves and contact the technical service.



Always use a dedicated power supply circuit; never use a power supply shared with other devices.



Always install an earth leakage circuit-breaker; failure to install this device could cause electric shock.



For the connection, use a sufficiently long cable to cover the entire distance without any connection; do not use extensions and do not apply other loads on the power supply, rather, always use a dedicated power supply circuit.



When the electrical cables are connected, make sure that the cables are arranged so that they do not press excessively on covers or electrical panels; any incomplete connection of the covers may cause overheating of the terminals.



Make sure that the earthing connection is set up; do not earth the device on distribution pipes. Momentary high intensity overcurrents may damage the unit.



Installations made outside of the warnings set forth herein or use outside of the operating limits will instantly void the warranty.



Make sure that commissioning is carried out by personnel authorised by the company (see commissioning request form)

1.5 CONFORMITY

The CE marking (applied on each machine) certifies compliance with the following Community standards:

- Low Voltage Directive 2014/35/EC
- Electromagnetic Compatibility Directive 2014/30/EC
- Ecodesign 2009/125/EC
- RoHS2 2011/65/EU
- WEEE 2012/19/EC

1.6 RANGE

Code	Total Flow Rate/renewal air flow rate	Type of installation
AP20048W	up to 620 m3/h	Horizontal

1.7 IDENTIFICATION



- The unit can be identified by the rating plate attached to the front bottom panel.
- On the packaging there is another identification rating plate with the unit model and the shipping references.
- The rating plate on the packaging is not valid for tracking the product over the years after sale.

The removal, deterioration and illegibility of the rating plate attached to the unit makes machine identification and ordering spare parts very difficult, and therefore all future maintenance.

1.8 CONSTRUCTION FEATURES

ASPIRCOMFORT CLASS 620H WI-FI is a fan unit complete with heat recovery unit dedicated to air renewal without wasting energy.

The unit is particularly suitable for single rooms where ducted systems are not possible.

FRAME

Self-supporting sheet metal frame with polyethylene insulated interior.

HEAT EXCHANGER

Polypropylene high efficiency cross flow counter current exchanger.

Low freezing temperatures and operation down to -25°.

Very high exchange efficiency.

FANS

Brushless forward curved centrifugal fans with electronic motor and modulating control.

Very high efficiency and low noise levels.

FILTERS

ePM1 70% filters with low head loss.

Easily removable by removing the lower outer panels.

FREE COOLING

Free cooling inside the unit with generous air flow and damper with motorised actuator.

ELECTRICAL PANEL

Electric panel complete with control board for 4 fan speeds, antifreeze, automatic bypass, temperature probes, post-heat coils and automatic dirty filter signal.

Control panel mandatory for unit operation with capacitive touch for installation on 503 box or wall.

EFFICIENCY

Thanks to its construction features and components, it is able to reach recovery efficiency of more than 90%.

In the winter and summer seasons there is considerable energy recovery of the renewal air introduced into the room.

1.9 DESCRIPTION OF OPERATION

The unit is a decentralised fan system with heat recovery, with the following characteristics and special features:

- it promotes healthy ventilation in offices, schools, businesses, allowing correct air renewal of the rooms and extracting excess humidity and unpleasant odours;
- it provides considerable energy savings for heating thanks to the efficiency of the heat recovery unit of more than 90%;
- the epm1 class filters, with low head loss, guarantee outdoor air filtering which is crucial for people with allergies;
- electronic speed control motors guarantee low electrical energy consumption;
- thermal and acoustic insulation;
- easy access for inspection and maintenance through panel with closures;
- antifreeze protection;
- control unit with display;
- set-up for easy connection to the mains and remote control.

1.10 STATE OF SUPPLY

The supply includes:

- recovery unit complete with fans installed inside the unit;
- polypropylene counter current exchanger pre-inserted inside the unit;
- ePm1 class filters pre-inserted inside the unit;
- electrical box with set-up for connecting terminal board;
- brackets for ceiling / wall installation;
- labels/stickers (safety pictograms, air connection identification, CE marking...) already on the unit;
- installation, use and maintenance manual.

1.11 REQUIREMENTS FOR START-UP



Before start-up make sure there are no foreign bodies inside the unit.
Check the fastenings of the closing panels and inspection doors.
Check the electrical power supply and the earthing of the unit.

1.12 DISASSEMBLY AND DISPOSAL



Do not take down or dispose of the product on your own. Disassembly, demolition and disposal of the product must be carried out by authorised personnel in accordance with local regulations.



ATTENTION:

Important information for environmentally sound disposal of the device.



The symbol of the crossed-out wheeled bin indicates that the products must be collected and disposed of separately from household waste at the end of its useful life.
The user must, therefore, either return the end-of-life equipment to the appropriate separate collection centres for electronic and electrotechnical waste or return it to the dealer when purchasing new equipment of an equivalent type, on a one-for-one basis. Appropriate separate collection for subsequent recycling, treatment and environmentally sound disposal of discarded equipment helps to avoid possible negative effects on the environment and health and promotes the recycling of materials from which the equipment is made. Illegal disposal of the product by the user entails application of the administrative sanctions set out in Legislative Decree No 22/1997* (Article 50 et seq. of Legislative Decree No 22/1997).

2. INSTALLATION

2.1 INSTALLATION CONDITIONS



The unit must be installed based on national and local regulations governing the use of electrical devices and based on the following indications:

- install the unit inside residential buildings with room temperature between 0°C and 45°C;
- avoid areas near sources of heat, steam, inflammable and/or explosive gases and particularly dusty areas;
- install the unit in a place that is not subject to frost (the condensation water must be discharged not frozen, at a certain slope, using a trap);
- do not install the unit in zones with a high relative humidity rate (such as bathroom or toilet) to avoid condensation on the external surface;
- choose a place of installation where there is enough room around the unit for the connections of the air ducts and to perform maintenance activities;
- the consistency of the ceiling/wall/floor where the unit will be installed must be suitable for the weight of the unit and not cause vibrations.

The room chosen for installation must have:

- outdoor air duct connections;
- 230V single-phase electrical connection;
- connection for the condensation discharge.



2.2 UNIT POSITIONING

The unit can be installed close to the wall with the pipes directly to the outside, or away from the wall with a minimum of ducting to get the pipes to the outside;

DUCTED INSTALLATION

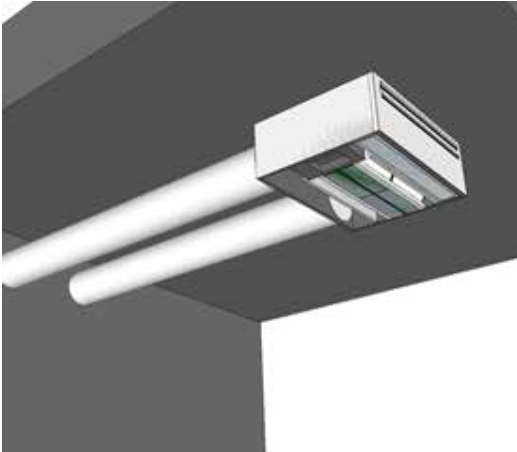

For ducted installation, leave the dn250mm male fittings on the unit which will be used to connect the pipes to the outside;

A maximum of 8 metres of ducting is possible for ducted installation;

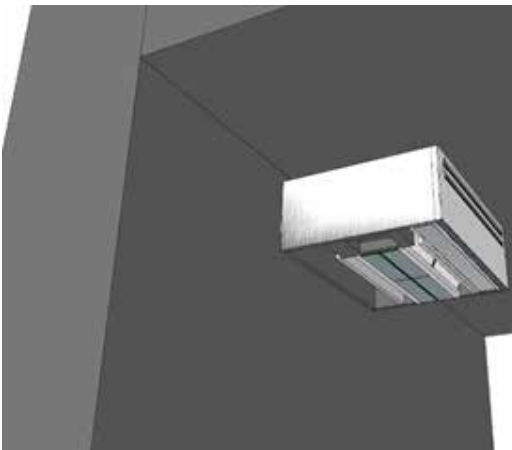

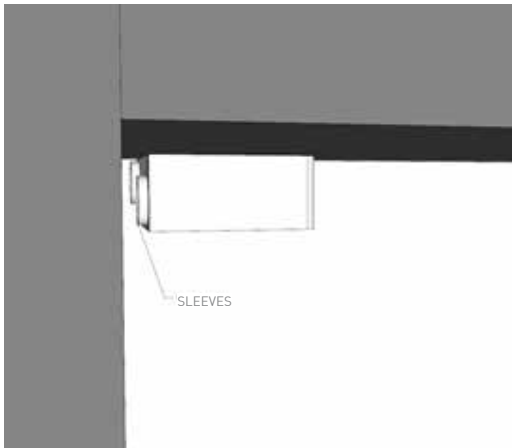

For non-ducted installation, the unit does not have ducting but is installed directly adjacent to the wall with direct holes to the outside;

In this case it is possible to leave the fittings if the centring of the holes outwards is very precise, or to remove them to bring the unit into contact with the wall;

TEMPLATE FOR CEILING HOLES

A template is provided for easy drilling of the holes for mounting the unit:

- Position the installation template on the ceiling
- Mark or drill directly according to the dowel, threaded rod used;
- Provide enough space to perform maintenance activities: it must be possible to open the cover of the unit (from below).

Do not mount the unit with the sides in direct contact with walls to avoid possible contact noise.

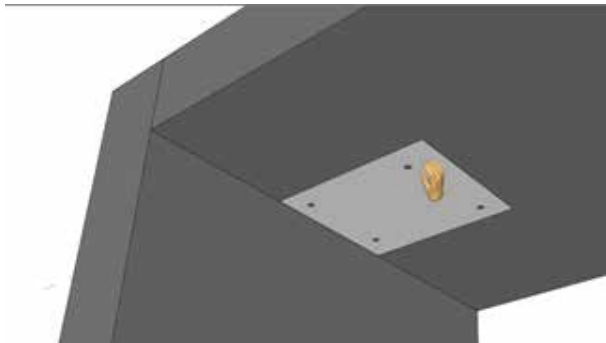
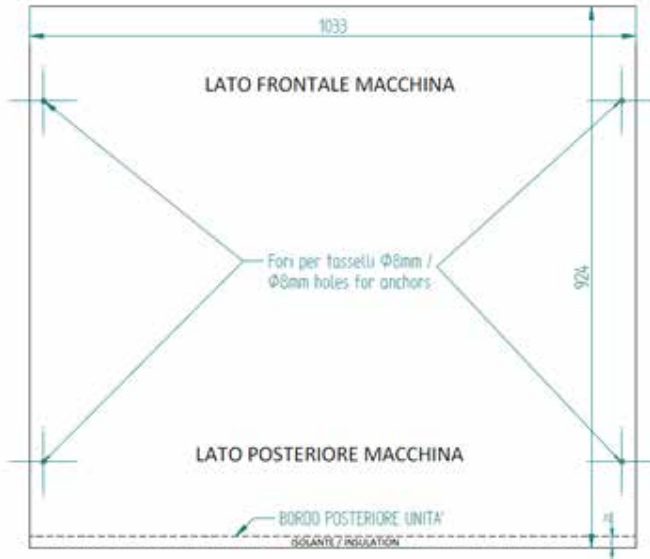

TEMPLATE FOR WALL HOLES

A template is provided for easy drilling of the unit's wall holes

- Position the wall installation template;
- Mark and drill two holes in the wall for outdoor air and indoor air outlet;
- Prepare the condensate discharge if it is conveyed directly to the outside with the air passage holes;
- Provide enough space to perform maintenance activities: it must be possible to open the cover of the unit (from below).

Do not mount the unit with the sides in direct contact with walls to avoid possible contact noise.

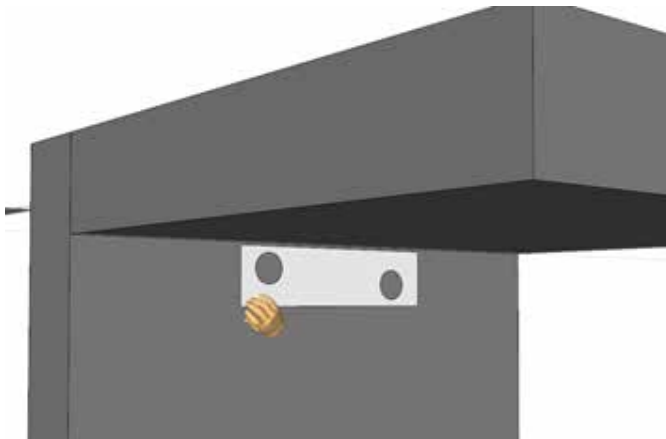
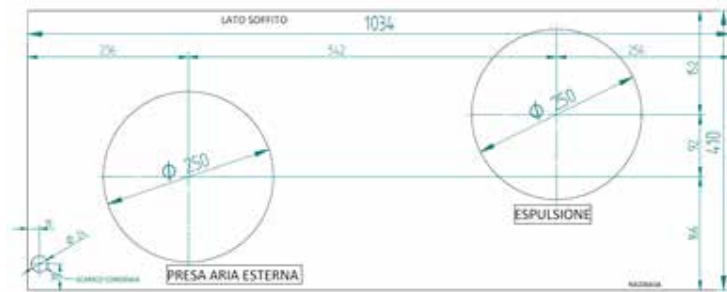

PREPARATION FOR CEILING UNIT POSITIONING

To mount the unit on the ceiling, it is necessary to:

- Remove the front discharge grille by pressing upwards on the 3 locking points of the grille to remove it;

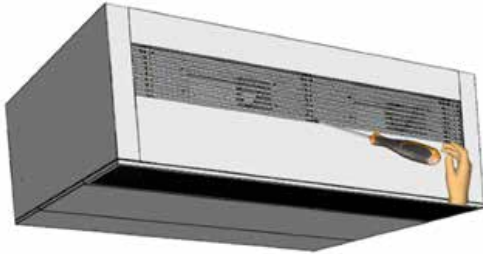

- Remove the 4 screws of the two aesthetic sides under the grille;

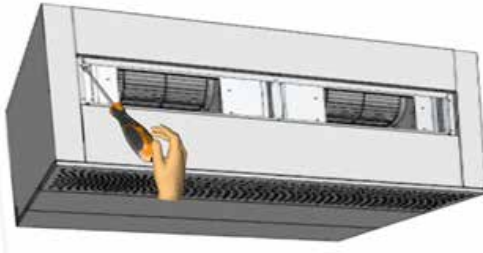

- Pull the side towards the front of the unit to release the rear fixings;

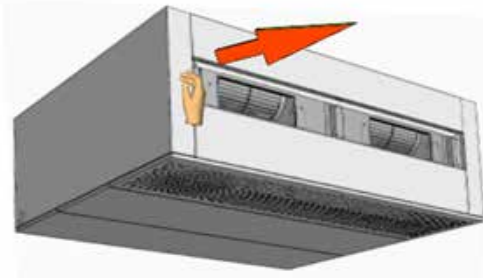

- Provide enough space to perform maintenance activities: it must be possible to open the cover of the unit (from below).

Do not mount the unit with the sides in direct contact with walls to avoid possible contact noise.

CEILING INSTALLATION

After preparing the fastenings with threaded rods or dowels, proceed as follows:

- Raise the unit and secure it to the bars using the nut and washer on the 4 brackets on the sides;
- Level the unit by tilting it 1-2° towards the condensate discharge on the left side by adjusting the height of the fixing on the brackets;
- Provide enough space to perform maintenance activities: it must be possible to open the cover of the unit (from below).

Do not mount the unit with the sides in direct contact with walls to avoid possible contact noise.

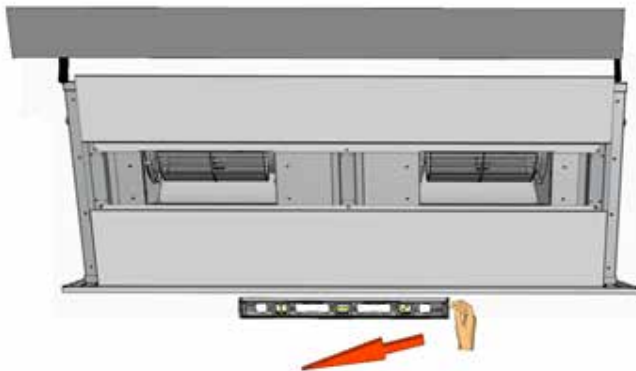
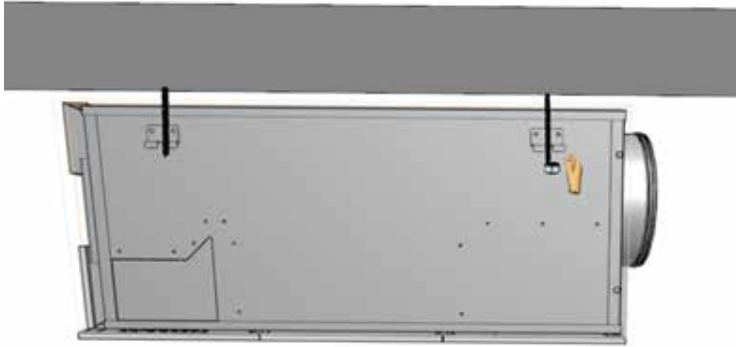



2.3 CONDENSATE DISCHARGE CONNECTION

Because of the heat recovery system (the exhaust air is cooled by the air supplied into the heat exchanger), the humidity contained in the internal air condenses inside the unit.

For correct operation of the heat recovery unit, it is necessary to connect one condensate discharge to the hydraulic system or disposable drain to the outside. Also, in order for the condensation water to correctly flow out and avoid air from being sucked in, the condensation discharge must always feature a special trap installed by the installer;

For installation of the condensation discharge, follow these rules:

- set up a slope of at least 2% to the discharge pipe;
- allow the possibility of disconnecting the discharge pipe for any maintenance (especially with ceiling installation);
- make sure that the discharge end of the pipe is at least below the level of the trap water;
- make sure that the trap is always full of water and at a sufficient height (at least 30-40mm).

On the machine, the drain is located on the left-hand side;

A Dn20 silicone tube is supplied inside the side panel, with a length of 80 mm to facilitate exit from the machine and connection to the condensate discharge system.

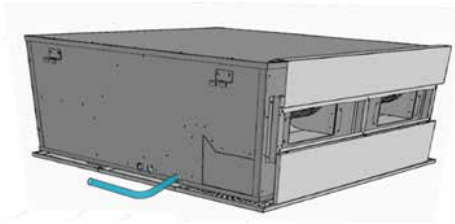

There are two options for exiting to the side, either to the rear or to the side;

Remove the part that is chosen for the condensate discharge and pass the pipe through that point.

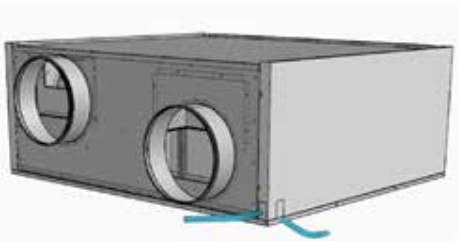

ATTENTION

To horizontal sections for condensate discharge with direct installation to the outside;

If water stagnates and outside temperatures are below 0°, there is a danger of the discharge freezing and therefore possible internal water leakage.

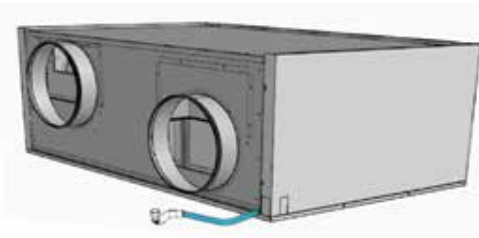

3 AERAULIC CONNECTIONS



3.1 AERAULIC ORIENTATIONS

The unit is equipped with 2 circular male connections \varnothing 250mm for outdoor air and expulsion to the outside; To correctly connect the air ducts, refer to the following diagram and stickers on the unit.

- As seen in the unit positioning section, there are two installation options:
- Units with a minimum distance from the external wall and external ducting;
 - Units close to the wall without ducting to the outside but with direct outlets.

External side

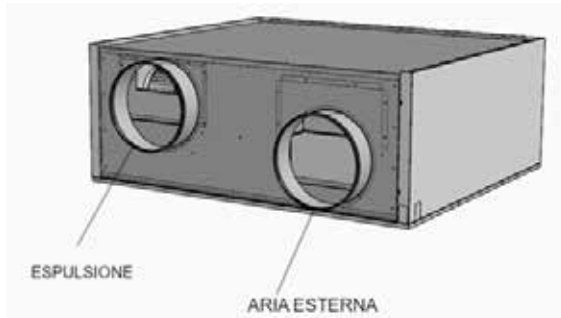

Internal side

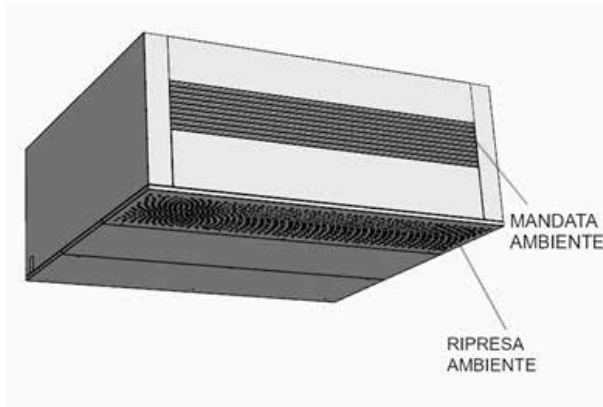

4 ELECTRICAL CONNECTIONS



4.1 GENERAL

- Before starting any operation to perform the electrical connection make sure that the unit is not electrically powered.
- Perform the necessary electrical connections referring exclusively to the wiring diagram attached to this manual.
- Install a suitable cut-off and breaker device exclusively serving the unit.
- It is essential for the unit to be efficiently earthed. The manufacturer will not be held liable whatsoever for the failure to comply.
- Check that the electrical components chosen for installation (main switch, breakers, cable size and terminals) are suitable for the electrical power of the installed unit and that they take into account the start-up currents of the compressor in addition to the maximum achievable load. The relative data is stated on the attached wiring diagram and on the unit's rating plate.
- It is forbidden to enter the unit with electrical cables except where specified in this file.
- Use duly-sized electrical cables and conductors that comply with the regulations in force in the various countries.
- Strictly avoid feeding through the electrical cables so that they are directly touching pipes or parts inside the unit.
- After the first moments of operation, check the tightness of the power supply terminal screws.

Table for power supply line sizing.

Power supply	V/Ph/Hz	230/1/50
Max absorbed current	A	3.5

4.2 POSITIONING AND PROCEDURES OF THE CONNECTIONS

On the machine, the electrical connections are located on the left-hand side; A 3x1.5mm power supply cable and a cable for the unit's remote panel with a 4-pin connector and a length of 10m are supplied;



There are two options for exiting to the side, either to the rear or to the side; Remove the part that is chosen for the electrical cable outlet and route the connections there;

For the electrical connection:

- Remove the screws from the front panel and take the front panel down;
- Use the two cable glands on the bottom side of the unit to enter with electrical cables inside the unit;
- Use electrical cables with double insulation in the passage through to the electrical box;
- Enter the electrical box with the cables and set up the electrical connections;

Make sure that the cables do not touch the fan impellers;

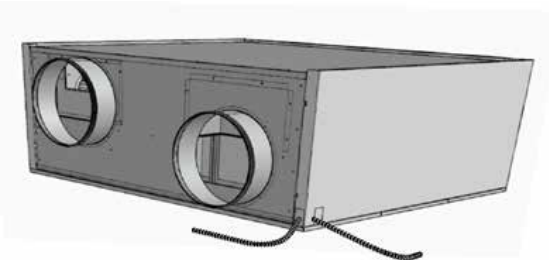

The electronic board is located on the lower central part of the unit where any auxiliary connections can be made;



Pe electrical auxiliary connections

- Remove the bottom panel screws and remove the centre bottom panel itself after removing the two outer bottom panels;
 - Use the two cable glands on the left side of the unit to enter with electrical cables inside the unit;
 - Use electrical cables with double insulation in the passage through to the electrical box;
 - Enter the electrical box with the cables and set up the electrical connections.
- Make sure that the cables do not touch the fan impellers.

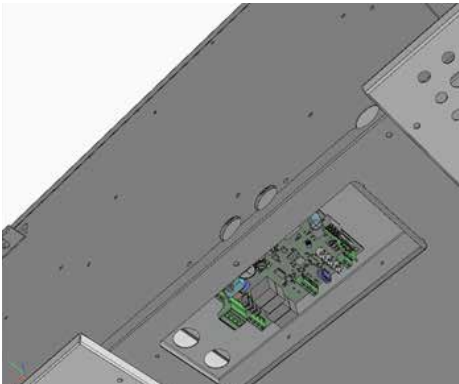

4.3 UNIT WIRING DIAGRAMS

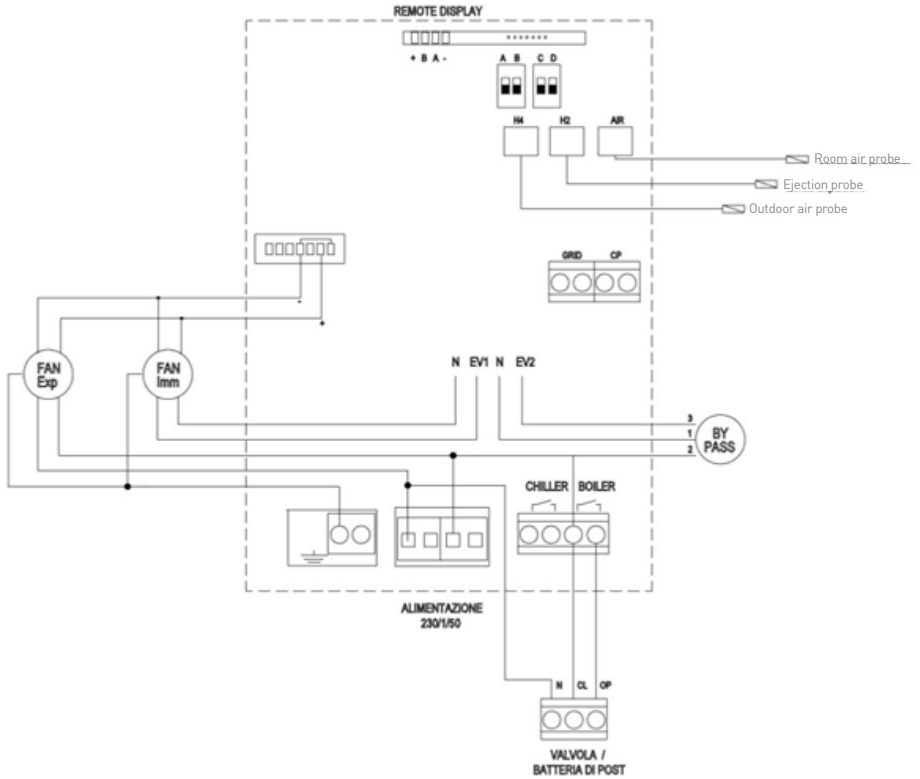

CONNECTIONS SET UP BY THE CUSTOMER

GRID	n.a.	n.a.
CHILLER	n.a.	n.a.
N - CL - CP	n.a.	n.a.
REMOTE DISPLAY	Remote control (4 wires)	
REMOTE ON OFF (ON DISPLAY)	n.a.	n.a.

4.4 CONTROL UNIT CONNECTION

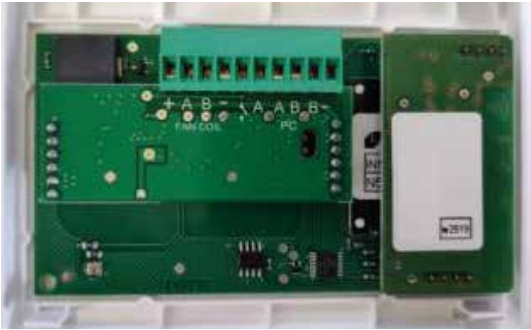

The control unit has the possibility of connection to a WIFI network and management of the unit via a dedicated APP.

The board uses a capacitive touch remote control to manage all of the functions of the unit.

The connection of the control unit to the unit is via 4-wire 0.75/1mm shielded/braided cable.

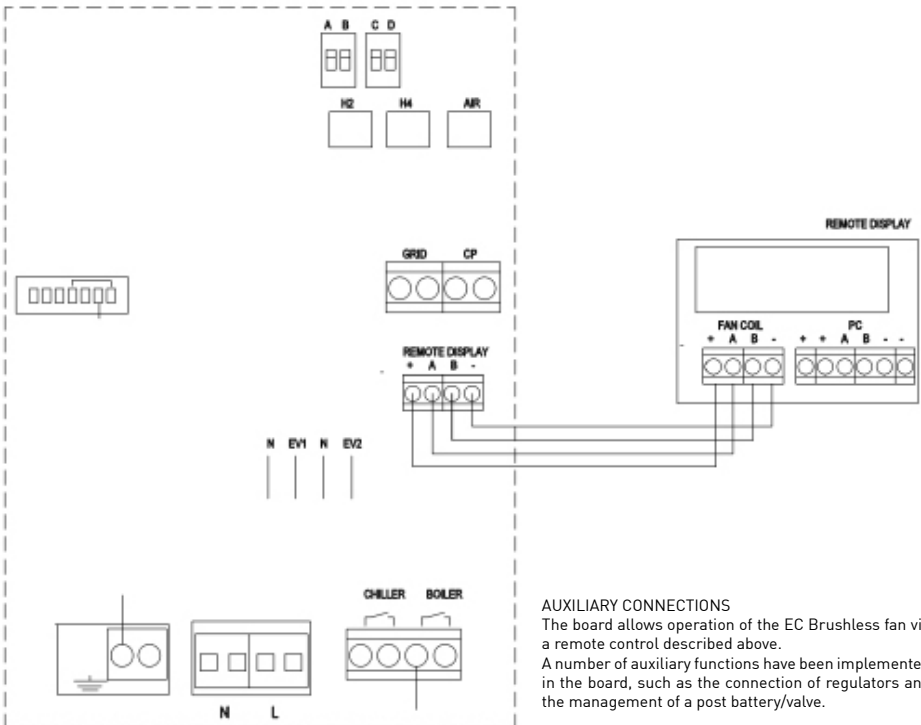

AUXILIARY CONNECTIONS

The board allows operation of the EC Brushless fan via a remote control described above.

A number of auxiliary functions have been implemented in the board, such as the connection of regulators and the management of a post battery/valve.

4.5 REMOTE ON OFF CONNECTION

The remote panel provides an ON OFF control with which the unit can be connected via a dry contact to a device for switching the unit on/off remotely such as a switch or timer.

Logic dictates:
 Contact closed: Unit OFF
 Contact open: Unit ON

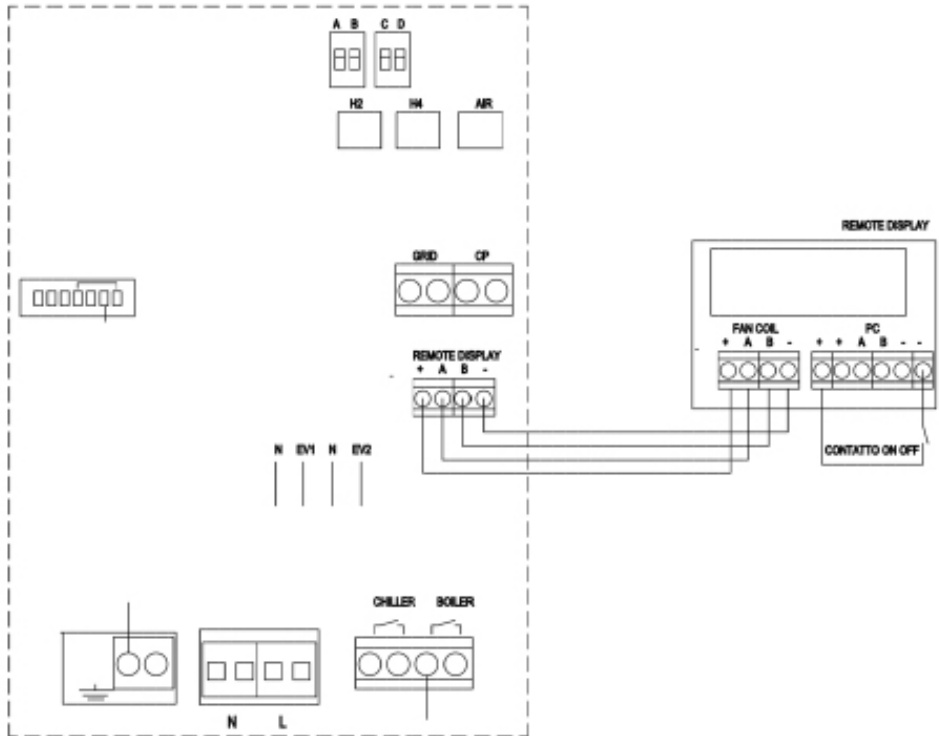



5 MAINTENANCE

To always guarantee correct and optimal unit operation, it is necessary to periodically perform all of the maintenance activities.

5.1 EPM1 FILTER CLEANING OR REPLACEMENT

To replace the filters, or periodically clean them, do the following:

- cut off the power to the unit;
- open the lower outer covers by removing the fixing screws;
- then open the filter holder caps by removing the additional fixing screws;
- take out the dirty filters;
- gently insert the new ones;
- close the cover back up again with the relative knobs.

If the conditions of the filters allow it, it is possible to proceed with cleaning them using a vacuum cleaner or low pressure compressor.

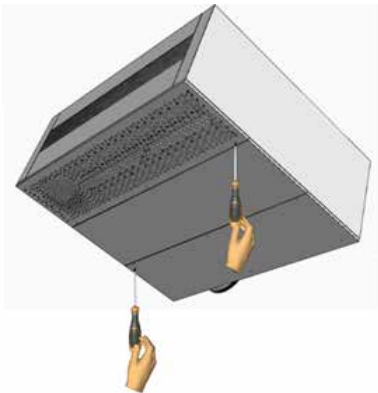

5.2 HEAT EXCHANGER CLEANING

It is advisable to check the status of the heat exchanger annually and clean it if necessary. This must only be done by qualified personnel (installer).

To clean the heat exchanger proceed as follows:

- cut off the power to the unit;
- open the lower covers by removing the fixing screws;
- remove the bottom panel by removing the additional fixing screws;
- remove the filters to gain access to the screws for removing the condensate tray;
- remove the clamp and disconnect the condensate discharge;
- remove the screws securing the condensate tray, and slide the condensate tray and exchangers downwards.

Caution! Caution! Never touch the exchanger fins, handle the exchanger by holding it only by the closed sides.

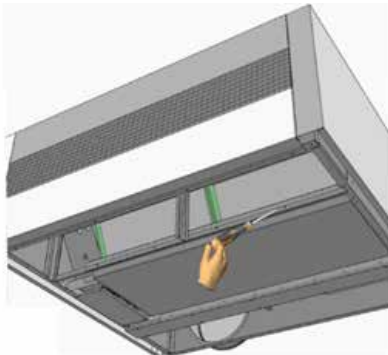
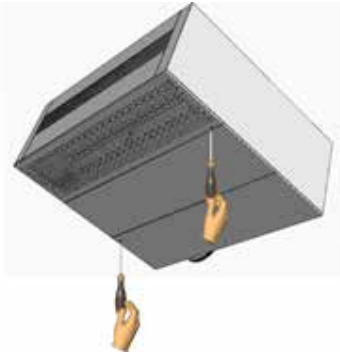

5.3 GENERAL UNIT CLEANING

It is advisable to occasionally check and possibly clean the fans of the condensation discharge and the inside walls of the unit. These activities must only be carried out by qualified personnel (installer).

For cleaning you can use a vacuum cleaner, a cloth slightly dampened with water, a soft bristle brush or a low pressure compressor.

Caution! There are small metal clips on the blades to balance them, DO NOT remove them.

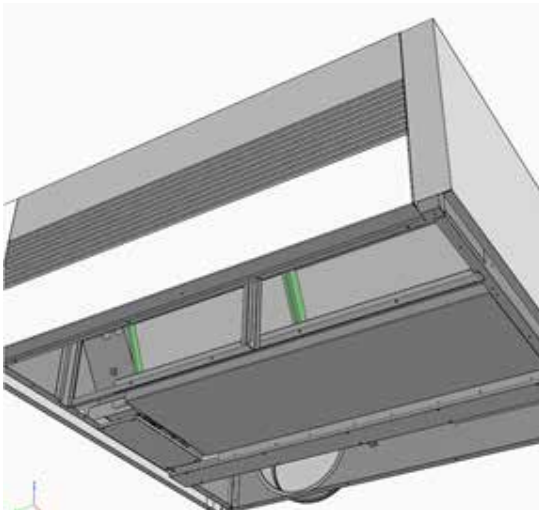

6 ALARMS

In case of any problems or failures, take note of any error code appearing on the electronic control unit or remote control screen, take note of the model and the serial number of the unit you possess (data provided on the identification plate attached on the side of the unit) and contact the installer.

6.1 PROBLEMS WITHOUT ANY INDICATION OF THE ERROR ON THE DISPLAY

PROBLEM	CAUSE	REMEDIES
The fans are not on	Power is not connected	Check for power supply on the fan
	The fan speed control device is not working	Check the fan speed control device
	Incorrect electrical connections	Check that the fan is not overheated and in thermal protection
	The fans are under thermal protection	
Insufficient air flow rate or useful pressure	Clogged filters	Clean the filters
	Insufficient rotation speed	Increase the rotation speed
	Clogged pipes or exchanger	Clean the pipes or exchanger
Insufficient exchanger efficiency	Clogged exchanger fins	Clean the exchanger surfaces
Excessive vibration and noise	Incorrect unit installation	Check the unit's brackets and fixings
	Incorrect pipe installation	Check pipe brackets and fixings
	Imbalance of fan impeller	Check the status of the fan impellers
Water leaking from the unit	Clogged condensate discharge	Clean the condensation discharge
	Incorrectly installed trap	Check whether the trap is installed correctly
Difficult start-up	Power supply voltage too low	Check that the power supply voltage is not below 10% of the rating plate's rated voltage
	Insufficient motor torque	Power the unit with the dampers partially closed so as to reduce the motor's starting torque. If it starts up correctly, replace the motor with a more powerful one.

6.2 ALARM SIGNALLING

A list of all alarms managed by the application follows.

The presence of an alarm has two display modes:

- an error code on the control display;
- a LED on the electronic board showing a flashing sequence with the type of alarm present.

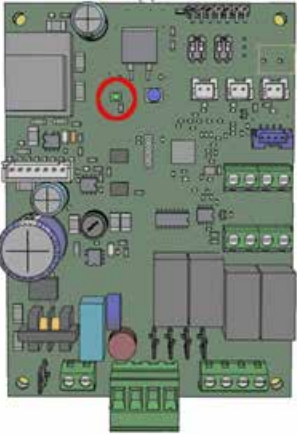

1 UNIT BOARD ALARM SIGNALLING LED



2 CONTROL UNIT ALARM SIGNALLING

6.3 DISPLAY ALARMS

Below is the table of unit malfunctions signalled by the remote display or by the flashing of the LED on the board.

CODE	DESCRIPTION	CAUSE	SOLUTION	BOARD FLASHES
E1	AIR recovery probe alarm	Probe breakage or failure to read	Check probe connection or replace probe	1 flash – off 3 seconds
	Fan alarm	Faulty fan connector or no feedback signal	Check the connection of the fan connector to the board Replace fan control cable	2 flashes – off 3 seconds
	Exhaust probe H2 alarm	Probe breakage or failure to read	Check probe connection or replace probe	3 flashes – off 3 seconds
	Outdoor air probe H4 alarm	Probe breakage or failure to read	Check probe connection or replace probe	5 flashes – off 3 seconds
	Connection with remote display alarm	Remote display connection error	Check electrical connections Check that A and B are not reversed Verify correct insertion of the display connection board on the main board	Led Off
	Remote display communication alarm	No communication between display and board for at least 300 seconds.	Check the status of the filter and press and hold the on-off button to reset the signal; Check that A and B are not reversed Verify correct insertion of the display connection board on the main board	6 flashes – off 3 seconds

FANTINI COSMI S.p.A.

Via Dell'Osio, 6 - 20049 Caleppio di Settala, Milan, Italy
Tel. +39 02 956821 | Fax +39 02 95307006
E-mail: export@fantinicosmi.it