

# ASPIRCOMFORT CLASS 620V WI-FI

## SINGLE ROOM HEAT RECOVERY VENTILATION UNIT

- For commercial applications, schools, offices
- Very high recovery efficiency >90%
- Vertical floor installation
- Integrated Wi-Fi control unit

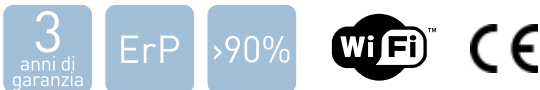

ASPIRCOMFORT CLASS is a fan unit complete with heat recovery unit dedicated to air renewal without wasting energy. The unit is particularly suitable for single rooms where ducted systems are not possible.

Thanks to its construction features, ASPIRCOMFORT CLASS 620V WI-FI is able to reach recovery efficiency of more than 90%.

In the winter and summer seasons there is considerable energy recovery of the renewal air introduced into the room.

## FEATURES

- Self-supporting sheet metal frame with polyethylene insulated interior.
- Polypropylene high efficiency cross flow counter current exchanger. Low freezing temperatures and operation down to -25°.
- Brushless forward curved centrifugal fans with electronic motor and modulating control. Very high efficiency and low noise levels.
- ePM1 70% filters with low head loss. Easily removable by removing the lower outer panels.
- Free cooling inside the unit with generous air flow and damper with motorised actuator.
- Management of 3 fan speeds + Auto.
- Wi-Fi control unit installed on board, with the possibility of management via App, equipped with sensors for monitoring temperature, relative humidity (RH%), volatile organic compound (VOC) concentration and carbon dioxide (CO<sub>2</sub>) concentration.
- The unit is equipped with a power cable with Shuko plug.

## UNIT ORDERING CODES

Code	Model	Description
AP20047W	ASPIRCOMFORT CLASS 620V WI-FI	Heat recovery unit for vertical installation with max. air flow rate 620 m <sup>3</sup> /h with Wi-Fi control

## UNIT CONFIGURATION

Code	Maximum flow rate	Installation
AP20047W	Up to 620 m <sup>3</sup> /h	vertical floor

### ■ REAR VIEW

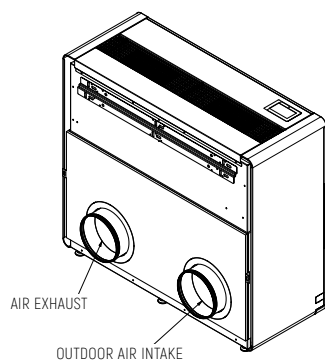

### ■ FRONT VIEW

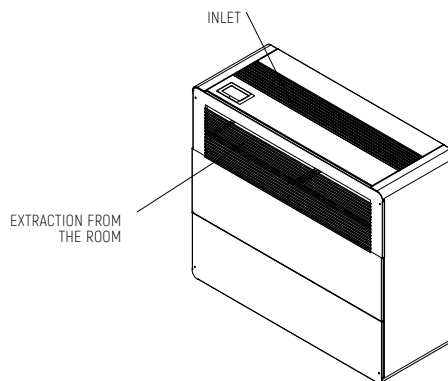

## CERTIFICATIONS

The CE marking (on each machine) certifies conformity with the following Community standards:

- Low Voltage Directive 2014/35/EC
- Electromagnetic Compatibility Directive 2014/30/EC
- Ecodesign 2009/125/EC

## ACCESSORIES

- 2 connections Ø 200 mm
- PE insulated mat
- 2 fixed grids Ø 200 mm for outside wall
- Installation template and wall mounting bracket

# DIMENSIONS AND FUNCTIONAL SPACES

MEASUREMENTS IN mm

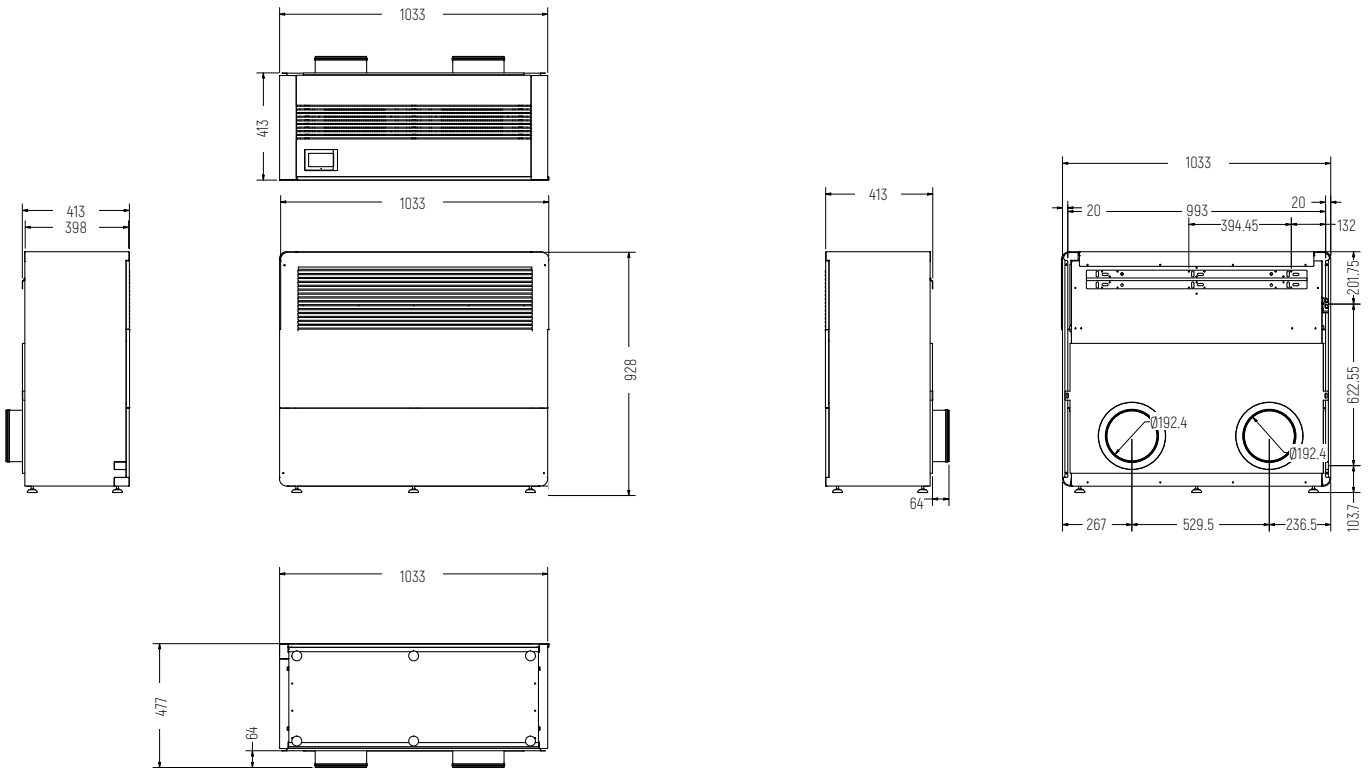

Width L	mm	1033
Depth D	mm	413
Height H (with feet)	mm	928
Diameter DN	$\varnothing$ mm	200
Weight	Kg	70
Condensation	$\varnothing$ mm	20

## TECHNICAL FEATURES

### Fans

Type of fans	Centrifugal blades forward directly coupled electronic motor - 0/10 V signal	
Number of fans	No	2+1
Air flow rate V3/V2/V1	m3/h	620 / 355 / 165
Useful pressure	Pa	15

### Heat exchanger

Type of exchanger	Countercurrent plates – polypropylene material	
Number of exchangers	No	2
Recovery efficiency EN13141-7	%	86.1
Recovery efficiency EN305	%	91.8

[Data according to UNI EN 13141-7 Indoor temp. 20° - Indoor humidity 28% - Outdoor temp. 7° - Outdoor humidity 72%]

### Filters

Type of filters	Pleated filters	
Filtration class	ePM1 70	

### Acoustic data

Sound power Lw transmitted by the structure	dB(A)	59
Sound pressure at 3 m V1 (low)	dB(A)	33
Sound pressure at 3 m V2 (average)	dB(A)	36
Sound pressure at 3 m V3 (high)	dB(A)	41
Sound pressure at 4 m V1 (low)	dB(A)	30.5
Sound pressure at 4 m V2 (average)	dB(A)	33.5
Sound pressure at 4 m V3 (high)	dB(A)	38.5

[Data according to UNI EN 3741 and UNI EN 3744]

### Electrical Data

Supply voltage	V	230 / 1 / 50 Hz.
Absorbed current	A	3.5
Power consumption	W	340
Protection rating	IP	X0
Power consumption V3 with 15Pa pressure and clean filters	W	165

### Dimensions

Width	mm	1033
Depth	mm	413
Height (with feet)	mm	928
Connections Diameter (DN)	mm	200
Condensation discharge	mm	20

## ADJUSTMENT (on board the machine)

### CONTROL UNIT FOR ASPIRCOMFORT CLASS WI-FI

- Smart Touch
- Management of 3 fan speeds + Auto
- WI-FI control unit and App
- On-board sensors for temperature monitoring, relative humidity (RH%), volatile organic compound (VOC) concentration and carbon dioxide (CO<sub>2</sub>) concentration
- Season setting
- Temperature set point

## SPECIFICATIONS

Very high efficiency, decentralised heat recovery fan unit, with compact dimensions for vertical floor installation.

Specific unit for commercial applications, schools, offices.

Tested and classified according to the European Ecodesign Regulation 2009/125/EC.

WI-FI control unit installed on board, with the possibility of management via App.

### CONSTRUCTION FEATURES

Self-supporting sheet metal frame with polyethylene insulated interior.

Polypropylene very high efficiency cross flow counter current exchanger with recovery efficiencies of more than 90%.

Brushless forward curved centrifugal fans with electronic motor and modulating control. Very high efficiency and low noise levels.

ePM1 70% filters with low head loss.

Free cooling inside the unit with generous air flow and damper with motorised actuator.

Compact dimensions for simplified installation with easily accessible bottom panel for maintenance and inspection.

200 mm diameter circular inlets with sealing gasket for easy installation.

Quick filter inspection and double discharge for condensation evacuation with trap supplied.

## ECODESIGN AP20047W ERP DATA

A	Supplier's name or trademark		Fantini Cosmi
B	Model identifier		ASPIRCOMFORT CLASS 620V WI-FI
C	Declared type		UVNR
D	Type of drive installed		Variable speed
E	Heat recovery system		Recovery
F	Thermal efficiency of heat recovery	%	86.1
H	Nominal flow rate	M <sup>3</sup> /s	0.172
I	SPF int	W / (m <sup>3</sup> /s)	634
J	Frontal speed	M/s	1.19
K	External pressure rating (Dps , ext)	Pa	15
L	Internal pressure drop (Dps , int)	Pa	194
M	Internal pressure drop	Pa	/
N	to components outside the ventilation (Dps , int)	%	31
O	Fan static efficiency as per	%	2.5 ext / 2.9 int
P	Energy classification of filters		F7/F7
Q	Position and description of the filter signal		Displayed on control panel
R	Sound power level	Lwa	59
S	Internet address disassembly instructions		<a href="http://www.fantincosmi.it">www.fantincosmi.it</a>