

# ECC15CA2 - ECC20CA2

## Single-jet compact heat meter

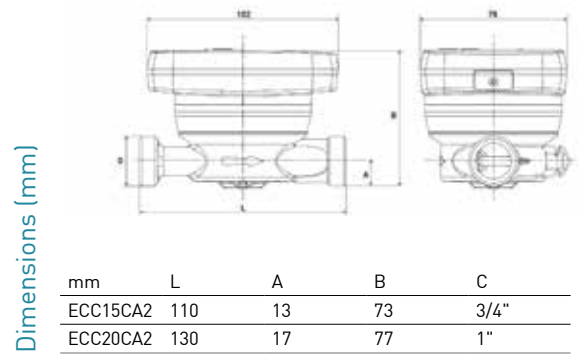

Compact heat energy meter that measures the amount of energy used for heating or cooling water supplied to individual consumers served by centralised systems, with integrated M-Bus Wireless OMS output.



	Nominal size inch - DN	Nominal flow rate Qp	Maximum flow rate Qs	Inputs (optional)	Communication interface	Communication interface (optional)
ECC15CA2	1/2" - DN15	1.5 m <sup>3</sup> /h	3.0 m <sup>3</sup> /h	2 with ECCMBIR	M-Bus Wireless	Wired with ECCMBIR
ECC20CA2	3/4" - DN20	2.5 m <sup>3</sup> /h	5.0 m <sup>3</sup> /h	2 with ECCMBIR	M-Bus Wireless	Wired with ECCMBIR
ECCMBIR	2 pulse inputs and wired M-Bus output module for ECC15CA2 - ECC20CA2 heat meters					
1592022	Meter connection DN15					
1592023	Meter connection DN20					

## INSTALLATION

The compact heat meter must be mounted on the return pipe of the system.

Horizontal, vertical and inclined installation.

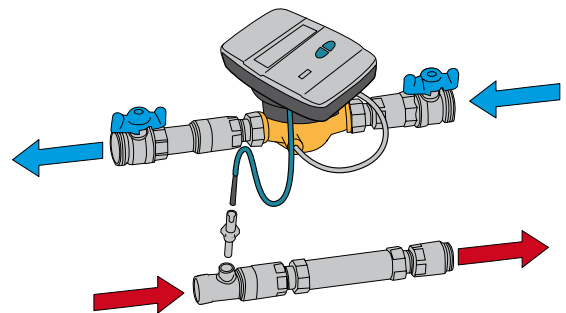

EXAMPLE OF INSTALLATION ON RETURN PIPE.

# REGULATIONS AND APPROVALS

Approved according to MID 2004/22/EC - MI004 compliant with EN1434.  
Accuracy Class 2; Environmental Class A (E<sub>1</sub>;M<sub>1</sub>)

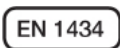

## OPERATION

The single-jet turbine, driven by the flow of water circulating through it, allows the flow rate in circulation to be determined by the turbine's speed.

Fantini Cosmi heat meters use an innovative turbine speed detection system based on the inductive principle, which makes the instrument not defraudable by external magnetic fields and extremely accurate over time.

The system supports certified and tamper-proof platinum Pt1000 thermal probes.

It is possible to apply a communication module code ECCMBIR to Fantini Cosmi heat meters code ECC15CA2 and ECC20CA2 to allow the connection of 2 external utilities with pulse inputs (e.g. DHW and AFS) to the meter itself and communicate all consumption data via M-BUS EN13757-2/3 output.



## PRESSURE DROP DIAGRAM

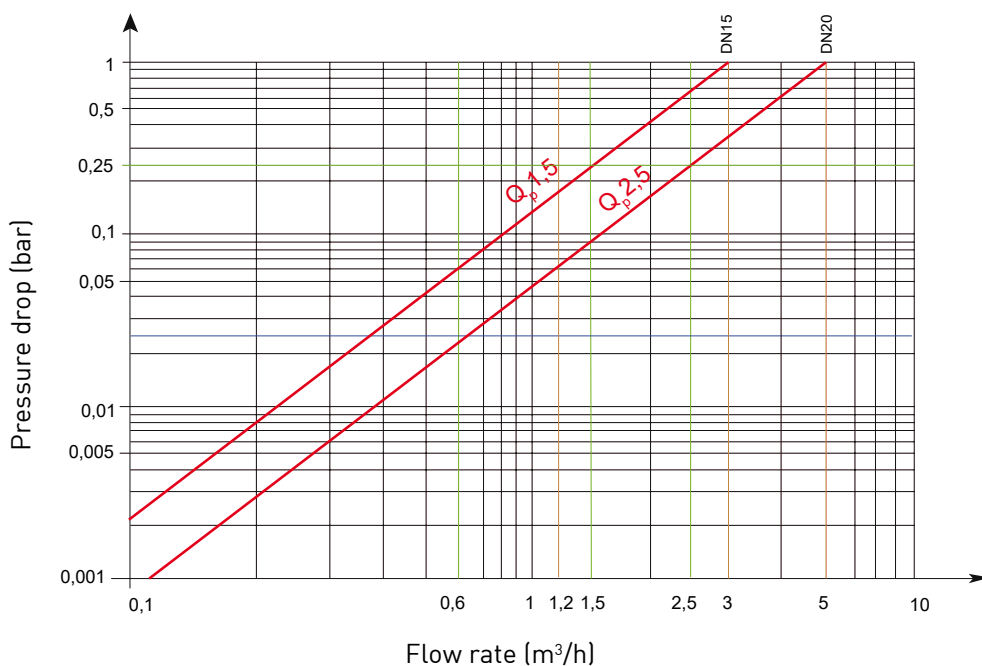

# FEATURES

---

Nominal flow rate:  $Q_n$  1.5 to 2.5.

Compact dimensions for installation in tight spaces.

Installation on the return pipe.

Power supply: lithium battery.

Operating duration: 10\* years.

Type of probes: Pt 1000.

Temperature range of the volumetric heating unit: 1 to 90 °C.

Measurable heating temperature difference:  $\Delta t$  3 - 70 K.

Ambient temperature: 5 - 55 °C.

Temperature range of the volumetric cooling unit: 0.2 - 90 °C.

Measurable cooling temperature difference:  $\Delta t$  0.2 - 90 K.

LC display: 8 + special characters.

Units of measurement: J, MJ, GJ, kWh, MWh for energy.

2 pulse inputs for DHW volumetric meters.

1 Pulse output for energy.

OMS Wireless M-Bus communication interface EN13757-4, M-Bus conforming to EN-1434-3 optional.

Fittings included.

IP54 degree of protection.

Weight: ECC15CA 680 g, ECC20CA 750 g.

\* Battery life is highly dependent on the working time window set during the configuration process and on environmental conditions.

# SPECIFICATIONS

---

## ECC15CA2

Compact heat meter for detecting and counting thermal energy in heating and cooling systems. Model type Fantini Cosmi code ECC15CA2. Brass body with single-jet turbine for flow measurement. Dry watchmaking.  $T_{max} = 90^{\circ}\text{C}$ .  $Q_p=1.5 \text{ m}^3/\text{h}$ .  $Q_i=30 \text{ l/h}$ . Mounting on return pipe with 1/2" M connection. PT1000 type immersion temperature probes mounted on brass probe holders with M10x1 connection. Cable length 1.5m. 360° swivelling calculation unit. 8-digit LCD display. Two front keys for reading data: display of total and instantaneous energy and volume consumption with settable units of measurement (J, MJ, GJ, kWh, MWh), instantaneous reading of measured quantities, error and tampering management. Two pulse inputs for reading external meter consumption. Volume calculated with impulse weight  $K=1$ . Data transmission with OMS EN13757-4 standard wireless M-Bus serial output for remote reading and optional M-Bus EN 1434 (requires code ECCMBIR). Battery-powered with 10-year service life. IP54 degree of protection. Horizontal installation, accuracy class 2. Conforms to the European Measuring Instruments Directive 2004/22/EC (MID).

## ECC20CA2

Compact heat meter for detecting and counting thermal energy in heating and cooling systems. Model type Fantini Cosmi code ECC20CA2. Brass body with single-jet turbine for flow measurement. Dry watchmaking.  $T_{max} = 90^{\circ}\text{C}$ .  $Q_p=2.5 \text{ m}^3/\text{h}$ .  $Q_i=50 \text{ l/h}$ . Mounting on return pipe with 3/4" M connection. PT1000 type immersion temperature probes mounted on brass probe holders with M10x1 connection. Cable length 1.5m. 360° swivelling calculation unit. 8-digit LCD display. Two front keys for reading data: display of total and instantaneous energy and volume consumption with settable units of measurement (J, MJ, GJ, kWh, MWh), instantaneous reading of measured quantities, error and tampering management. Two pulse inputs for reading external meter consumption. Volume calculated with impulse weight  $K=1$ . Data transmission with OMS EN13757-4 standard wireless M-Bus serial output for remote reading and optional M-Bus EN 1434 (requires code ECCMBIR). Battery-powered with 10-year service life. IP54 degree of protection. Horizontal installation, accuracy class 2. Conforms to the European Measuring Instruments Directive 2004/22/EC (MID).